



www.whytebikes.co.uk



www.whytebikes.co.uk



146
T-120
E-120

**Supplementary Service Manual
Edition 1: August 2010**

NOTES (continued)

www.whytebikes.co.uk 
DESIGNED IN THE U.K.

8.0: TORQUE SETTINGS

Rear Quad-Link Suspension:	Nm	lbs.ft
Link Outer Bearing Caps	2.0 (Min) / 3.0 (Max)	1.5 (Min) / 2.2 (Max)
M8 AeroSpace Nuts	17.0 (Min) / 19.0 (Max)	12.5 (Min) / 14.0 (Max)
M6 Countersunk Cap-screws (146 Y-link)	9.0 (Min) / 10.0 (Max)	6.6 (Min) / 7.4 (Max)
Rear Dropout Assembly		
Chain ring Bolts (E-120 Dropout)	15.0 (Min) / 25.0 (Max)	11.0 (Min) / 25.0 (Max)
M6 cap-screws (T-120S or 146S Dropout)	10.5 (Min) / 12.5 (Max)	7.7 (Min) / 9.2 (Max)

Torque explained: If no suitable Torque Wrench is available a Torque of 5 lbf.ft can be obtained by applying a force of 5lb, with a Spring Balance, to the end of a spanner, 1 Foot in length.

IMPORTANT: For all other torque settings, refer to the specific manufacturers information bundled with this manual, or alternatively, refer to the specific manufacturers website for further information.

9.0: NOTES

Table of Contents

- 1.0 Introduction
- 2.0 Geometry:
 - 2.1 146
 - 2.2 T-120
 - 2.3 E-120 (with 120 fork)
 - 2.4 E-120 (with 130 fork)
- 3.0 Preparations for riding:
 - 3.1 Making Adjustments
 - 3.2 Getta-Grip Seat Clamp
 - 3.3 Set up of Fork
 - 3.4 Set up of Rear Damper
- 4.0 Safety.
- 5.0 Lubrication:
 - 5.1 Getta-Grip Seat Clamp
 - 5.2 General Lubrication
- 6.0 Servicing the Rear Suspension:
 - 6.1 Removing the Rear Shock and Swinging Arm
 - 6.1.1 From E-120 or T-120
 - 6.1.2 From 146
 - 6.2 Stripping and Re-assembling Front and Rear Quad-Links
 - 6.2.1 From E-120 or T-120
 - 6.2.2 From 146
 - 6.2.3 Extraction of KP Bearings
 - 6.2.4 Insertion of KP Bearings
 - 6.2.5 Re-Assembly of Quad-Links
 - 6.3 Re-assembling the Rear Suspension
 - 6.3.1 Correct Orientation of Front and Rear Quad-Links
 - 6.3.2 Re-Assembly of Rear Suspension (E-120 or T-120)
 - 6.3.3 Re-Assembly of Rear Suspension (146)
- 7.0 Servicing Whyte Modular Dropout Systems:
 - 7.1 Disassembly of Rear Modular Dropout
 - 7.1.1 From E-120
 - 7.1.2 From T-120 or 146
 - 7.2 Reassembly of Rear Modular Dropout
 - 7.2.1 To E-120
 - 7.2.2 To T-120 or 146
- 8.0 Torque Settings.
- 9.0 Notes

1.0: INTRODUCTION

Thanks for choosing Whyte. We hope you will enjoy all the benefits its advanced design and engineering will bring to your riding experience.

This manual will guide you through the set-up, safety and maintenance procedures that are specific to your Whyte bike. For other more general information, we strongly advise that you also read thoroughly the General Instruction Manual that is also supplied with your new bike.

Also, please note that the specification of all the components that are fitted to your bike as standard may be obtained from the Whyte Bikes Brochure or alternatively from the Whyte Bikes website **www.whytebikes.co.uk**

Please remember, if you are in any doubt about your ability to correctly and safely service or repair your Whyte bike, do not ride it and instead get your local Whyte dealer to do the job safely and correctly.

Bundled with this manual, are the respective manufacturers instructions and manuals for the branded parts that are fitted to your Whyte bike. Please take time to study all the relevant instruction manuals to ensure you have a continually safe and well set-up bike before every ride, and to help you build up a relationship of knowledge between you and your Whyte Dealer.

Happy and safe riding,

Whyte design team. July 2010.

7.1: Removing the Rear Modular Dropouts from the Swinging Arm.

Tools Required: 5mm Allen Key
6mm Allen Key

7.1.1: From E-120

Reference figure 18. Both Left (4) and Right Hand (2) dropouts are a modular design, that can be replaced if damaged. They are each attached to the Swinging Arm (3) by two bolts (1a & 1b) . To remove either Right Hand (2) or Left Hand (4) dropout apply heat to the assembly - to reduce the Loctite strength - then using the 5mm Allen key for the outside bolts (1a) and 6mm Allen key for the Inside Bolts (1b), undo both bolts and remove them from the assembly. The Dropout (2 & 4) should now be detached from the Swinging Arm (3). Take care not to loose any of the components & also handle hot parts with care.

7.1.1: From T-120 or 146

Reference figure 19. Both Left (2) and Right Hand (3) dropouts are a modular design, that can be replaced if damaged. They are each attached to the Swinging Arm (4) by three cap-screws (1) . To remove either Right Hand (3) or Left Hand (2) dropout apply heat to the assembly - to reduce the Loctite strength - then using the 6mm Allen key undo all three bolts and remove them from the assembly. The Dropout (2 or 3) should now be detached from the Swinging Arm (4). Take care not to loose any of the components & also handle hot parts with care.

7.2: Assembling the Rear Modular Dropouts onto the Swinging Arm

Tools Required: 5mm Allen Key
6mm Allen Key
Torque Wrench
Loctite 638 retaining compound

7.2.1: To E-120

Reference figure 18. It is important to make sure the Swinging Arm (3) and Dropouts (2 & 4) are clean and free from mud, grease and other dirt, which could prevent the Dropouts (2 & 4) and Swinging Arm (3) from fitting together perfectly. Before assembling the bolts (1a & 1b), apply a small amount of Loctite 638 retaining compound to the threads of each of the bolts (1a & 1b), as well as to the outside of the Female Chain Ring Bolts (1b) so an even covering is achieved. Next, assemble the parts as shown in Fig 17. making sure the Bolts (1a & 1b) are correctly positioned as shown. Using the Torque Wrench, tighten the bolts (1a & 1b) to the correct torque as specified in Section 8.0. Wipe off any excess retaining compound.

7.2.2: To T-120 or 146

Reference figure 19. It is important to make sure the Swinging Arm (4) and Dropouts (2 & 3) are clean and free from mud, grease and other dirt, which could prevent the Dropouts (2 & 3) and Swinging Arm (3) from fitting together perfectly. Before assembling the screws (1), apply a small amount of Loctite 638 retaining compound to the threads of the screws (1) and Swinging Arm (3). Next, assemble the parts as shown in Fig 18. making sure the screws (1) are correctly positioned as shown. Using the Torque Wrench, tighten the screws (1) to the correct torque as specified in Section 8.0. Wipe off any excess retaining compound.

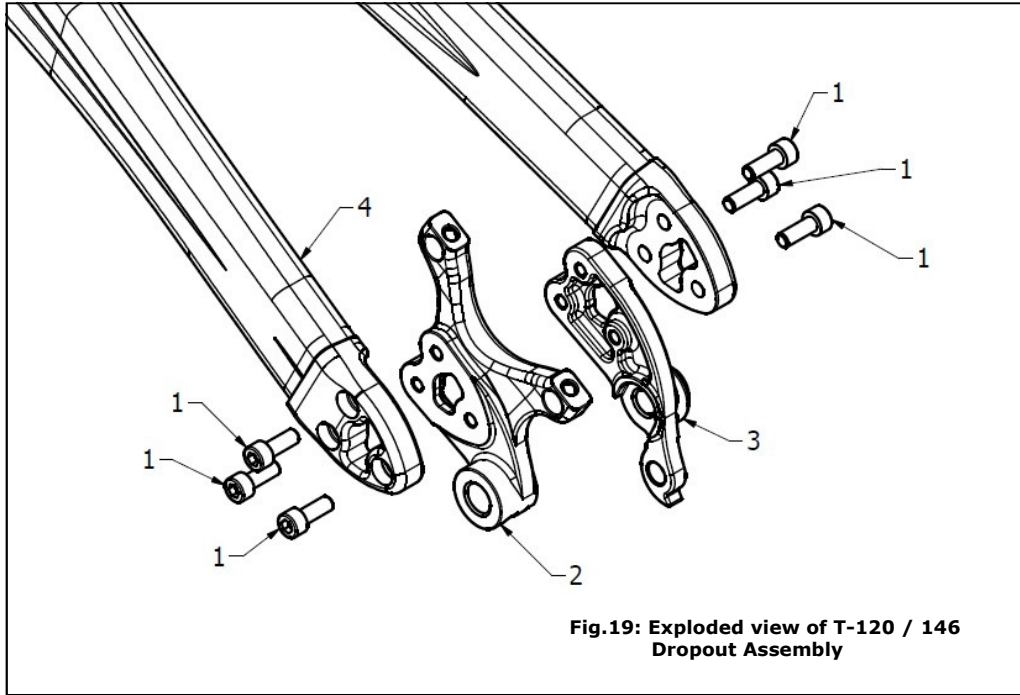

Item	Description
1	M6 x 16 long Cap Screw
2	Dropout, Q/R Modular Type, brake side.
3	Dropout, Q/R Modular Type, derailleur side
4	Swinging Arm Mounting Point

2.0: GEOMETRY

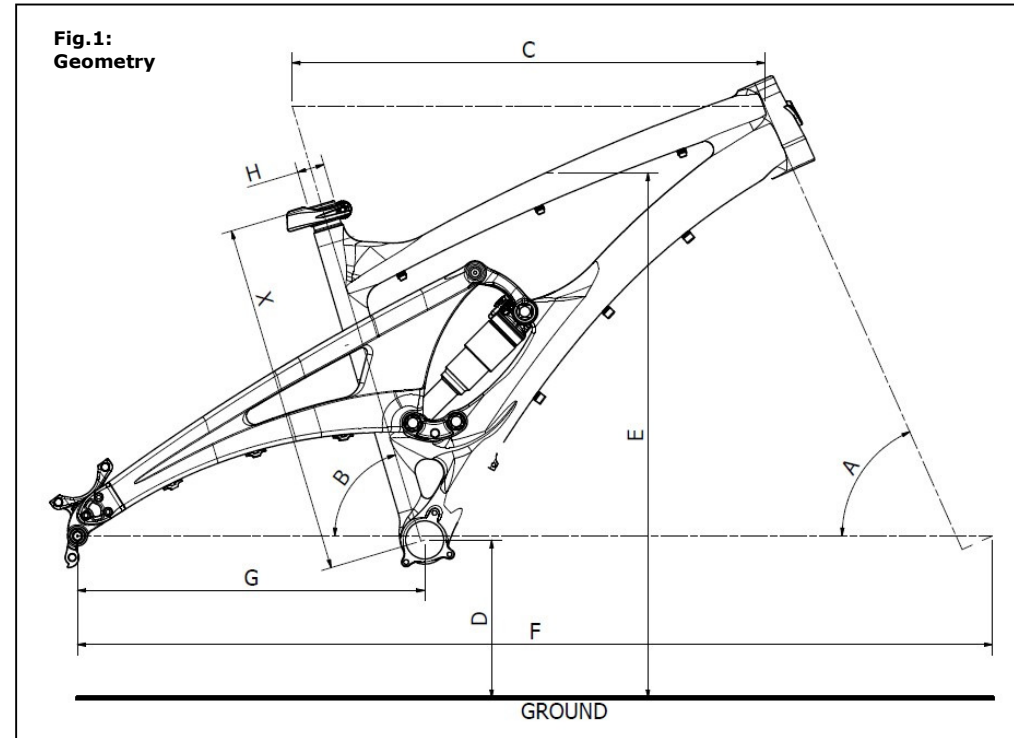

2.1: Whyte 146 Geometry

Frame Size	X	Small	Medium	Large
Head Angle	A	66.0°	66.0°	66.0°
Seat Angle	B	73.5°	73.5°	73.5°
Top Tube	C	575.7mm	599.0mm	624.4mm
BB Height*	D	338mm	338mm	338mm
Stand Over	E	795mm	803mm	810mm
Wheel Base	F	1135.5mm	1159.4mm	1184.8mm
Chain Stay	G	440mm	440mm	440mm
Seat Post	H	30.9mm	30.9mm	30.9mm

Notes:
Geometry shown here is 'Showroom' i.e. without rider aboard the bicycle. 'With Sag' geometry is with rider after correct sag is set at front and rear. Please refer to suspension set up for information on how to achieve the correct sag of the fork and rear damper.

* BB height with Ø686mm tyres fitted (2.5" / 60-559)

2.2: Whyte T-120 Geometry

Frame Size	X	Small	Medium	Large
Head Angle	A	68.0°	68.0°	68.0°
Seat Angle	B	73.0°	73.0°	73.0°
Top Tube	C	578.7mm	598.2mm	610.8mm
BB Height*	D	341.5mm	336.5mm	334.5mm
Stand Over	E	756m	777mm	800mm
Wheel Base	F	1093.4mm	1119.3mm	1135.1mm
Chain Stay	G	425mm	425mm	425mm
Seat Post	H	27.2mm	27.2mm	27.2mm

Notes:
Geometry shown here is 'Showroom' i.e. without rider aboard the bicycle. 'With Sag' geometry is with rider after correct sag is set at front and rear. Please refer to suspension set up for information on how to achieve the correct sag of the fork and rear damper.

* BB height with Ø673mm tyres fitted (2.2" / 52-559)

7.0: SERVICING THE WHYTE MODULAR DROPOUT SYSTEMS.

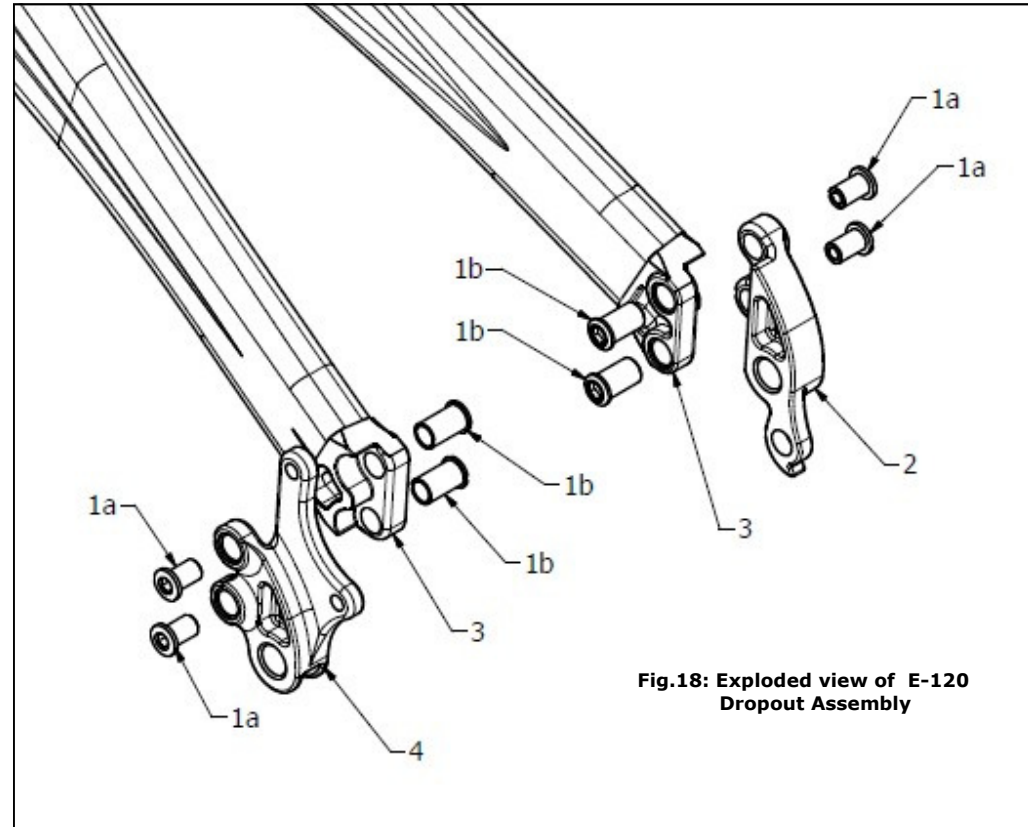

Fig.18: Exploded view of E-120 Dropout Assembly

Item	Description
1a	Chain ring Bolt Male
1b	Chain Ring Bolt Female
2	Dropout, Q/R Modular Type, Derailleur side
3	Swinging Arm Mounting Point
4	Dropout, Q/R Modular Type, Disc side

6.3.3: REASSEMBLING THE REAR SUSPENSION (146)

Reference figure 17. The re-assembly of the rear suspension is basically the reverse of the dis-assembly procedure. Starting with the rear 55mm centre-to-centre Quad Link (9), ensure the Quad-Link (9) is correctly orientated (see figure 13) and pass an 90mm long M8 shaft (4) through the Quad-Link (9) and Main Frame (7). Next take the Rear Shock and assemble the front mount of the Rear Shock using SKF LG/AF anti fret paste on the contacting surfaces, into the forward shock mount of the Mainframe (7).

IMPORTANT. Ensure the damper is the correct way up, with any dials and levers facing upwards. Assemble the front Y-Link (8) onto the Mainframe (7), and pass an 90mm long M8 shaft (4) through the front Y-Link (8), the Mainframe (7) and through the front of the Rear Shock until the 90mm long M8 shaft (4) is showing out the other side of the front Y-Link(8). You should now have both front and rear links assembled onto the Mainframe (7), with the Rear Shock in position. For the front Y-Link (8) make sure that the two stepped shield washers (3, figure 10) are in place . Next, lower the Swinging Arm (10) onto the rear suspension assembly and position the Swinging Arm (10) onto the front Y-Link (8) first. Ensure that the stepped shield washers (3, figure 10) in the front Y-Link assembly (8) are not pushed out, as you lower the swinging arm into position. Pass the Ø9.5 x 25 long hollow pin (6) through the front of the Swinging Arm (10), the stepped shield washers (3, figure 10) and the front Y-Link (8), until it has passed though the other side. Next rotate the Swinging Arm (10) down to attach it to the rear Quad-Link (9) and the rear of the Rear Shock. Once you have the Swinging Arm (10) in the correct position, make sure that the rear Quad-Link (9), the Swinging Arm (10) and the Rear Shock though holes are all concentric with each other, and push through the 100mm long M8 shaft (3). Next re-fit the M8 AeroSpace Nuts (2) by screwing onto the ends of all M8 shafts (3 & 4). Also screw the M6 countersunk socket screws (5) into the ends of the Ø9.5 x 25 long hollow pin (6).

IMPORTANT: before final tightening of the M8 AeroSpace Nuts (2), it is important to make sure that there is a balanced amounts of thread showing through the M8 AeroSpace Nuts (2) on each side of the links. Using the 4mm Allen key or flat-bladed screwdriver in the end of the 90mm long M8 shafts (3 or *3), and the 10mm spanner, adjust all three M8 shafts (3 or 4) accordingly. Refer to Fig. 15.

Tighten all M8 AeroSpace Nuts (2) and Ø9.5 x 25 long hollow pins (6) to the recommended settings. (Refer to the Tightening torque settings in Section 7.0) Next make sure that there is still a substantial amount of Molykote 111 Silicon covering all the KP5AX Bearings. Lastly refit the Link Bearing Caps (1) by carefully screwing them into the link body. Take care not to cross thread the fine thread. Tighten all Link Bearing Caps (1) to the recommended settings. (Refer to the Tightening torque settings in Section 7.0). Wipe off any excess Molykote 111 Silicon from around the links and frame.

2.3: Whyte E-120 Geometry (with 120 Fork)

Frame Size	X	Extra-Small	Small	Medium	Large
Head Angle	A	69.6°	69.6°	69.6°	69.6°
Seat Angle	B	71.6°	71.6°	71.6°	71.6°
Top Tube	C	571.9mm	583.5mm	596.2mm	610.3mm
BB Height*	D	354mm	354mm	354mm	354mm
Stand Over	E	728mm	742mm	754mm	781mm
Wheel Base	F	1058.4mm	1070.7mm	1083.8mm	1098.8mm
Chain Stay	G	420mm	420mm	420mm	420mm
Seat Post	H	30.9mm	30.9mm	30.9mm	30.9mm

Notes:
 Geometry shown here is 'Showroom' i.e. without rider aboard the bicycle. 'With Sag' geometry is with rider after correct sag is set at front and rear. Please refer to suspension set up for information on how to achieve the correct sag of the fork and rear damper.
 * BB height with Ø673mm tyres fitted (2.2" / 52-559)

2.4: Whyte E-120 Geometry (with 130 Fork)

Frame Size	X	Extra-Small	Small	Medium	Large
Head Angle	A	68.7°	68.7°	68.7°	68.7°
Seat Angle	B	70.6°	70.6°	70.6°	70.6°
Top Tube	C	574.8mm	586.5mm	599.3mm	613.3mm
BB Height*	D	359.7mm	359.7mm	359.7mm	359.7mm
Stand Over	E	734mm	748mm	760mm	787mm
Wheel Base	F	1064.5mm	1076.7mm	1090.1mm	1104.8mm
Chain Stay	G	420mm	420mm	420mm	420mm
Seat Post	H	30.9mm	30.9mm	30.9mm	30.9mm

Notes:
 Geometry shown here is 'Showroom' i.e. without rider aboard the bicycle. 'With Sag' geometry is with rider after correct sag is set at front and rear. Please refer to suspension set up for information on how to achieve the correct sag of the fork and rear damper.
 * BB height with Ø673mm tyres fitted (2.2" / 52-559)

3.0: PREPARATIONS FOR RIDING

3.1: MAKING ADJUSTMENTS

Please refer to the specific component manufacturer's manual or published technical information about adjusting the components on your Whyte bike. Instructions may be downloaded from the relevant manufacturer's internet site, as shown in the table to the right.

If you are uncertain in any way, about making adjustments to any components on your Whyte bike, then **DO NOT RIDE YOUR BIKE**. Contact your Whyte dealer who will be able to advise you on how to go about setting up your Whyte for riding, and or making adjustments to the components fitted to your Whyte.

CST	www.csttires.com
Easton	www.eastonbike.com
Fi:zik	www.fizik.it
Formula	www.formulahubs.com
Fox	www.foxracingshox.com
Shimano	www.shimano.com
SRAM	www.sram.com
Sun Ringle	www.sun-ringle.com
TH	www.thindustries.com.tw
VP	www.vpcomponents.com
WTB	www.wtb.com

3.2: WHYTE GETTA-GRIP SEAT CLAMP

3.2.1: WHYTE GETTA-GRIP SEAT CLAMP SADDLE HEIGHT ADJUSTMENT

The Getta Grip seat clamp design is present on all models of Whyte full suspension mountainbikes. It is a patented design to allow adjustment of the saddle height by either the use of a QR Lever, or bolt-up method. This manual covers both of those styles of clamp design.

Item:	Description
1	Seat Clamp Band
2	T-Pad
3	Main Frame
4	Barrel Nut
5	M6 x 30mm Fastener
6	M6 Washer



IMPORTANT: before final tightening of the M8 AeroSpace Nuts (2), it is important to make sure that there is a balanced amounts of thread showing through the M8 AeroSpace Nuts (2) on each side of the Quad-Links. Using the 4mm Allen key or flat-bladed screwdriver in the end of the M8 Shafts (3 or *3), and the 10mm spanner, adjust all 4 M8 Shafts (3 or *3) accordingly. Refer to Fig. 16.

Tighten all M8 AeroSpace Nuts (2) to the recommended settings. (Refer to the Tightening torque settings in Section 7.0) Next make sure that there is still a substantial amount of Molykote 111 Silicon covering all the KP5AX Bearings. Lastly refit the Link Bearing Caps (1) by carefully screwing them into the link body. Take care not to cross thread the fine thread. Tighten all Link Bearing Caps (1) to the recommended settings. (Refer to the Tightening torque settings in Section 7.0). Wipe off any excess Molykote 111 Silicon from around the links and frame.

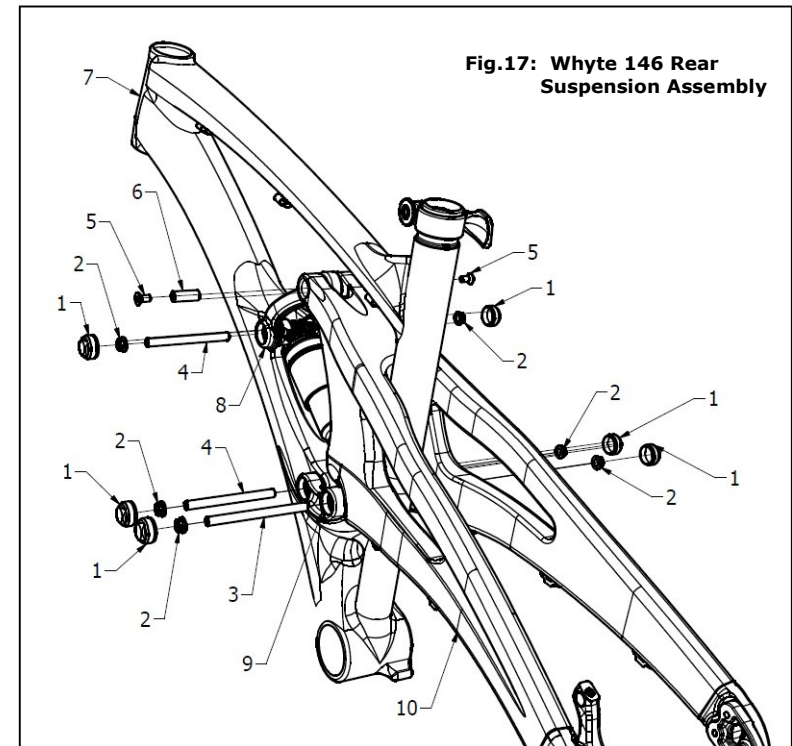

6.3.2: REASSEMBLING THE REAR SUSPENSION (E-120 or T-120)

Reference figure 15. The re-assembly of the rear suspension is basically the reverse of the dis-assembly procedure. Starting with the rear 50mm centre-to-centre Quad Link (6), for E-120 models made prior to 2011 check that the shield washers are in place (see items 2 in figure 9). Then ensure the Quad-Link (6) is correctly orientated (see figure 13) and pass an M8 Shaft (3 or *3) through the Quad-Link (6) and Main Frame (4). Next take the Rear Shock (Not Shown) and assemble the front mount of the Rear Shock using SKF LG/AF anti fret paste on the contacting surfaces, into the forward shock mount of the Mainframe (4).

IMPORTANT. Ensure the damper is the correct way up, with any dials and levers facing upwards. For the front 75mm centre-to-centre Quad Link (5), for E-120 models made prior to 2011 check that the shield washers are in place (see items 2 in figure 9). Assemble the front Quad-Link (5) onto the Mainframe (4), and pass an M8 Shaft (3 or *3) through the

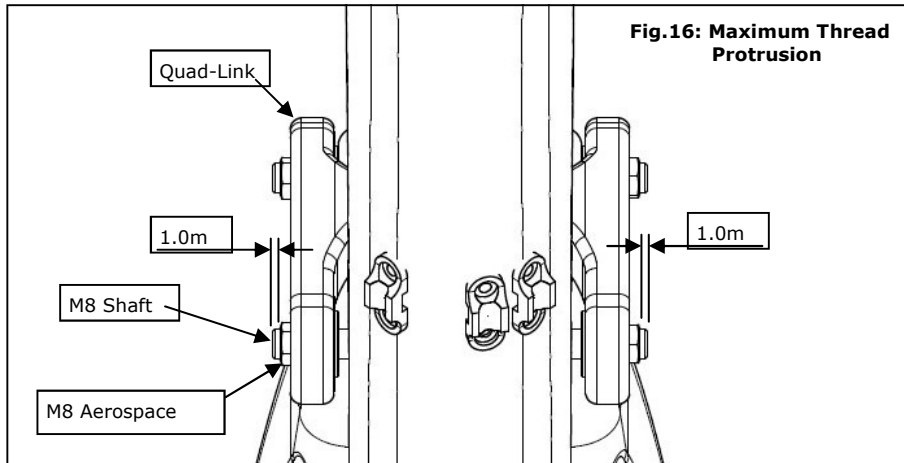

front Quad-Link (5), the Mainframe (4) and through the front of the Rear Shock until the M8 Shaft (3 or*3) is showing out the other side of the front Quad-Link(5). You should now have both front and rear Quad-Links assembled onto the Mainframe (4), with the Rear Shock in position. Next, lower the Swinging Arm (7) onto the rear suspension assembly and position the Swinging Arm (7) onto the front Quad-Link (5) first. Pass an M8 Shaft (3 or *3) through the front Quad-Link (5) and Swinging Arm (7) until it has passed though the other side. Next rotate the Swinging Arm (7) down to attach it to the rear Quad-Link (6) and the rear of the Rear Shock. For E-120 models made prior to 2011, ensure that the Middle Shield Washers (2, Fig.9) in the rear Quad-Link assembly are not pushed out, as you lower the swinging arm into position. Once you have the Swinging Arm (7) in the correct position, make sure that the rear Quad-Link (6), the Swinging Arm (7) and the Rear Shock though holes are all concentric with each other, and push through the last remaining M8 Shaft (3). Next re-fit the M8 AeroSpace Nuts (2) by screwing them onto the ends of all M8 shafts (3 or *3).

Bolt-up Type: Fig.2

Tools Required: 5mm Allen Key

(Note, refer to the seat-pin manufacturers instructions in conjunction with these notes). To adjust the seat height, using the 5mm Allen key, undo the M6 bolt (5) just enough to allow the seat-pin to slide freely up and down. Set the height to the desired level, and re-tighten the M6 bolt (5) with the 5mm Allen Key just enough so as to prevent the seat-pin from slipping down and twisting.

Item	Description
1	QR Lever Cam Grub Screw
2	QR Lever Cam
3	Whyte QR Lever
4	Plastic Shim
5	Main Frame
6	Seat Clamp Band
7	QR Adjuster Bobbin
8	QR Shaft
9	T-Pad

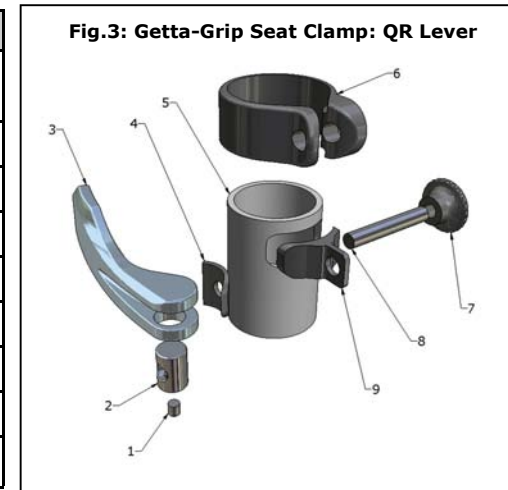

QR Lever Type: Fig.3

No tools required.

(Note, refer to the seat-pin manufacturers instructions in conjunction with these notes).

To Adjust the seat height with the QR Lever assembly fitted, simply undo the QR Lever (4) from the Closed position to the Open position. Next adjust the height of the Seat Pin to the desired level, and close the QR lever (4) to the from the Open position to the Closed position. The QR closing force can be adjusted by turning the QR Adjuster Bobbin (8) clockwise or anti-clockwise before closing the QR Lever (4).

3.2.2: WHYTE 146S & T-120S COCKPIT ADJUSTMENTS

Please refer to the specification chart and from there, the relevant manufacturers instructions to adjust the cockpit components before riding your 146s or T-120. This includes information on the Minimum insertion depth of the Seat Post in the frame.

3.3: SET UP OF FORK

*Tools Required: Good Quality Shock Pump.
Small Ruler*

The front suspension fork fitted to your Whyte bike will be pre-set with the standard settings. Before riding, you may need to adjust these setting. First is the Sag setting on the fork. This is to ensure the forks are set-up correctly for your own body weight, so the fork will perform as intended.

To set Sag on the front fork, you need to measure the amount the fork compresses when you sit on the bike in the normal riding position. See the table on the right for our recommendation of front fork sag on your Whyte bike. To achieve this you will need to adjust the air spring pressure inside the fork.

Model	Sag
E-120	20mm (16%)
T-120	
146	30mm (20%)

Refer to the specification tables in this manual, and then to the relevant fork manufacturers set up instructions to find how to adjust the air spring pressure in the fork. Using a shock pump, either add or remove air until Sag is correctly set.

Please note that for the detailed instructions for servicing and all matters relating to the forks fitted to your Whyte bike, please refer to the manufacturers instructions.

Rebound Damping adjustment:

This adjustment fine-tunes the speed at which the wheel returns to its normal ride height after hitting a bump. Refer to the relevant manufacturers instructions to find out how to adjust the rebound damping. To demonstrate the effect of this function, turn the adjuster to its slowest setting. Press down on the handlebars to compress the forks, then release the load. The suspension recovers very slowly to its original position.

Repeat the above with the adjuster turned to the fastest setting and the difference will be seen immediately the load is released. We recommend the optimum setting is to adjust the re-bound damping to be as slow as possible, but not so slow that the normal ride height is not recovered. On very rough terrain, if the bike becomes progressively lower as more bumps are hit then the re-bound damping is set too slow. On the other hand if the bike feels choppy and not plush then the re-bound damping is too fast. A bit of trial and error is needed to get the exact setting.

IMPORTANT SAFETY NOTE:

Always stop riding when making adjustments of any kind to the bicycle!

3.4: SET UP OF REAR DAMPER

*Tools Required: Good Quality Shock Pump.
Small Ruler*

Your Whyte bike is fitted with and air spring rear shock absorber. This means that the air

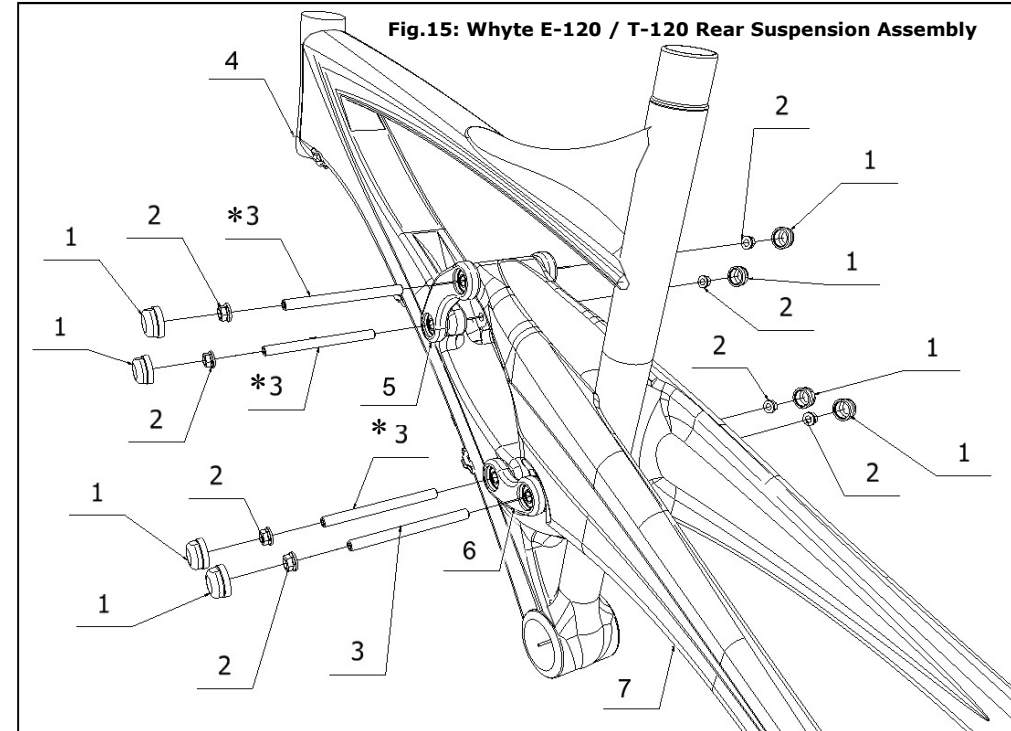

Fig.15: Whyte E-120 / T-120 Rear Suspension Assembly

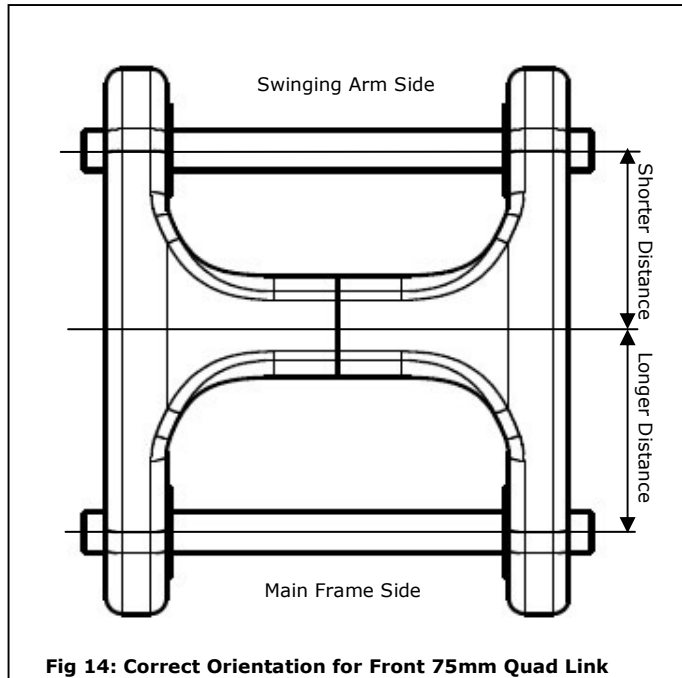

Fig 14: Correct Orientation for Front 75mm Quad Link

pressure in the shock absorber determines the spring rate. The correct 'sag' can be found using the sliding 'o' ring fitted to the shaft of the shock piston. Slide the 'o' ring against the shock body. Then gently sit on the bike in your normal riding position and with normal riding gear, including back pack if applicable, and also raise your feet off the floor. Carefully dismount and measure the distance the 'o' ring has moved away from the shock body. The optimum distance for the Quad-Link rear suspension system is shown in the table to the right. If there is less than that distance fit a shock pump and release air pressure. Conversely if there is greater than that distance, fit the shock pump and increase air pressure. Repeat the 'sag' test until the recommended sag distance is achieved.

Model	Sag
E-120 T-120	14mm (25%)
146	17mm (30%)

Rear Suspension Set-up - Rebound Damping:

When the damper unit is being compressed, this is known as the compression stroke. As the suspension unit recovers from compression back towards its full length, this is called the re-bound stroke. All the shocks fitted as standard to the Whyte full suspension mountainbikes have factory set compression damping, and manually adjustable rebound damping.

Rebound Damping Adjustment:

This adjustment fine-tunes the speed at which the rear wheel returns to its normal ride height after hitting a bump. Please refer to the relevant Shock manufacturers technical information to find out how to adjust the Shock. To demonstrate the effect of this, turn the adjuster to its slowest setting. Press down on the saddle to compress the suspension, then release the load. The suspension recovers very slowly to its original position.

Repeat the above with the adjuster turned to the fastest setting and the difference will be seen immediately the load is released. We recommend the optimum setting is to adjust the re-bound damping to be as slow as possible, but not so slow that the normal ride height is not recovered. On very rough terrain, if the rear of the bike becomes progressively lower as more bumps are hit then the re-bound damping is set too slow. On the other hand if the bike feels choppy and not plush then the re-bound damping is too fast. A bit of trial and error is needed to get the exact setting.

IMPORTANT SAFETY NOTE:

Always stop riding when making adjustments of any kind to the bicycle!

Platform Damping Adjustment.

The rear Shock fitted to your Whyte bike may have a facility to adjust the slow speed compression damping. Please refer to the relevant shock manufactures technical information to learn how to adjust these features. Please note, that the Whyte Quad-Link rear suspension system has been designed not to rely on excessive low speed compression damping to obtain efficient pedalling performance, and turning on too much low speed damping on the rear shock will compromise the suspensions sensitivity to small bump absorption and traction.

4.0: SAFETY

IMPORTANT: The following are intended to be advisory notes on the safe use of your Whyte bike. You should also read thoroughly the General Instruction Manual also supplied with your new bike. If at any stage you are uncertain about the safety or safe operation of the bike as a whole, or any specific component, then **DO NOT RIDE YOUR WHYTE** and instead please consult the specific component manufacturers instruction manual or your Whyte Dealer for advice.

Maximum Weight Limit (rider & luggage) for Whyte E-120, T-120 & 146:
18st. / 114kg

WARNING: As is the case with all mechanical components, the bicycle is subjected to wear and high stresses. Different materials and components may react to wear and stress fatigue in different ways. If the design life of a component has been exceeded, it may fail suddenly causing possible injury to the rider. Any form of crack, scratches and decolouring in highly stresses areas are showing that the component has exhausted its life time and has to be replaced. If you are in any doubt about one or more components on your Whyte **DO NOT RIDE YOUR BIKE**. Consult the specific component manufacturers literature, or take your bike to your local Whyte Dealer.

Designed for the following use:

The Whyte E-120 & T-120 have both been designed, tested and comply with BS EN 14766 Standard, for typical cross country mountain biking use. They have not been designed or tested for extreme down-hilling or free-riding.

The Whyte 146 bike has been designed, tested and complies with BS EN 14766 Safety Standard, for typical cross country and free-ride mountain biking use. It has not been designed or tested for extreme down-hilling.

6.3: REASSEMBLING THE REAR SUSPENSION.

6.3.1: CORRECT ORIENTATION OF FRONT AND REAR QUAD-LINKS.

Ensure that upon assembling the Quad-Links to the mainframe, that the links are orientated as shown in Figures 13 & 14. Both figures show E-120, but the link orientations also apply to T-120 and 146 as well.

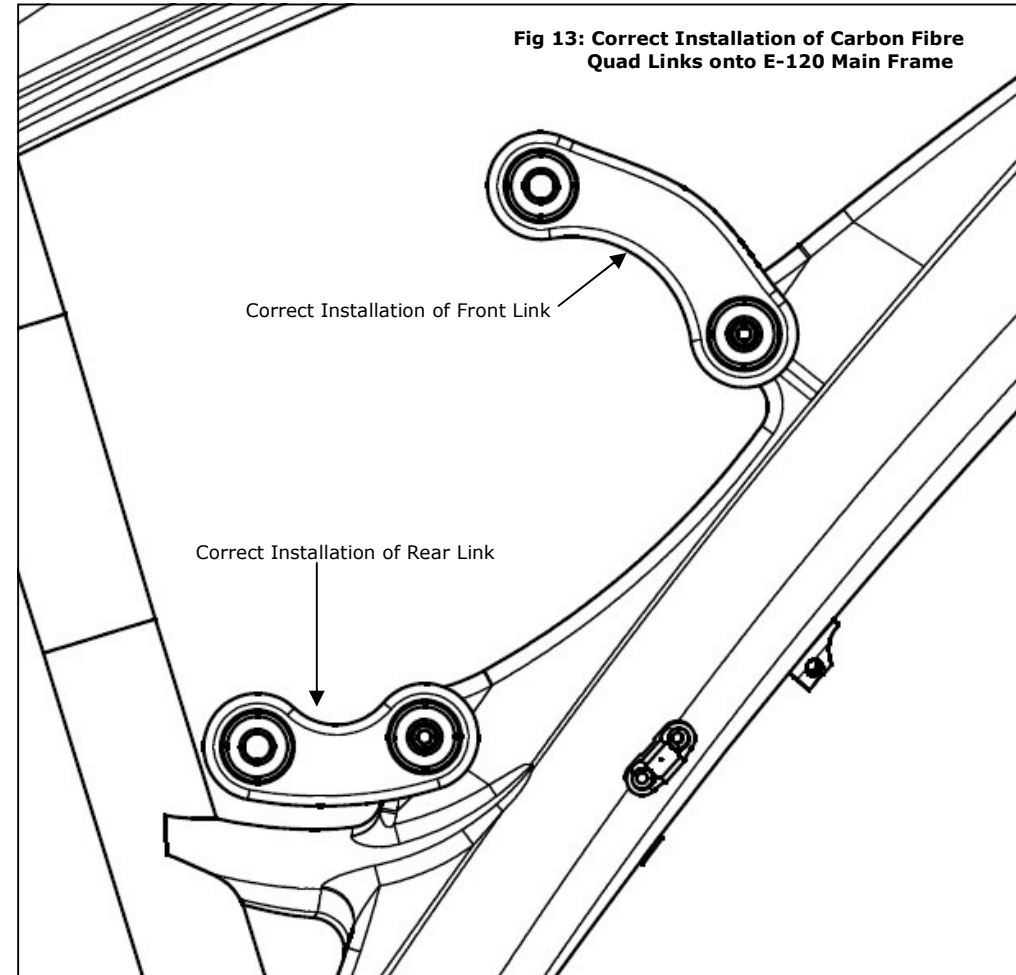

6.2.3: EXTRACTION OF KP BEARINGS

Tools required: Whyte KP5AX or KP6AX bearing press tool.
6mm AF Allen Key
10mm AF Spanner.

To remove the KP Bearings (4) from the Link Body (3). Assemble the parts as shown in Fig 11a. Using the 6mm Allen Key and 10mm spanner, tighten the assembly together until the KP bearing(4) is pressed out of the Link Body (3). Repeat on all other KP bearings.

Important note: the single KP6AX bearing in a "Y" link **MUST** be extracted the opposite end to the shoulder in the bore, see Fig. 12.

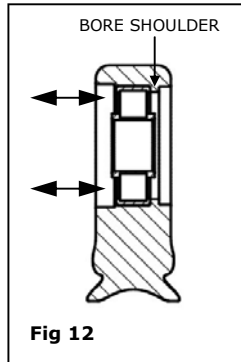

6.2.4: INSERTION OF KP BEARINGS

Tools required: Whyte KP5AX or KP6AX bearing press tool.
6mm AF Allen Key
10mm AF Spanner
Loctite 638

Before re-assembling both front and rear link assemblies, make sure all the components are clean from dirt and have been thoroughly de-greased. To press the KP bearings (5) into the Link Body (4) apply a small amount of Loctite 638 to the outside diameter of the KP bearing and to the inside Bearing bore of the Link Body (4). Next assembly the components as illustrated in Fig. 11b. It is very important to make sure the KP (5) bearing and Bearing Insertion tool 1 (3) are squarely seated against the Link Body (4). With great care, slowly tighten the M8 Socket head cap screw (7) with the 6mm Allen key and 10mm Spanner until you can see the KP bearing (5) being pressed squarely into the Link Body (4). Once the KP bearing is fully seated an you can no longer tighten the M8 Socket Head Cap Screw further, undo the nut and bolt and remove any excess Loctite from around the KP Bearing, particularly in any internal threads. Repeat for the remaining KP Bearings.

Important note: the single KP6AX bearing in a "Y" link **MUST** be inserted into the opposite end to the shoulder in the bore, see Fig. 12.

6.2.5: REASSEMBLY OF QUAD-LINKS

Tools required: Molykote Silicon 111

Apply a good quantity of Molykote 111 Silicon on top of the KP Bearings. The Molykote Silicon should completely cover each bearing and be applied on both sides of each bearing when it is in the Link Body.

For the 146S Y-link and pre-2011 E-120 links, assemble the shield washer components (2 see Fig.9 or 3 see fig. 10). If you have applied enough Molykote 111 Silicon, it should spread from under the shield washer components as they are positioned. Wipe this excess Silicon away from around the shield washer components.

APPLICATION OF SKF LG/AF ANTI-FRET PASTE

Once the Links has been assembled correctly, SKF LGAF 3 Compound *must* be applied to all outside faces of the shield washer components (2 see Fig.9, or 3 see fig. 10), that contact the Main Frame and Swinging Arm. It is additionally recommended to apply SKF LGAF 3 compound to the link contact surfaces on the Main Frame and Swinging Arm.

5.0: LUBRICATION

5.1: GETTA-GRIP SEAT CLAMP

5.1.1: BOLT-UP

Point	Description	Lubricant	Lubrication Interval
1	M6 x 30mm Fastener	Castrol LM or equivalent	Once a Month



5.1.2: QR STYLE

Point	Description	Lubricant	Lubrication Interval
1	Whyte QR Lever Cam Surface	Castrol LM or equivalent	After Every Ride
2	M6 QR Shaft	Castrol LM or equivalent	Once a Month

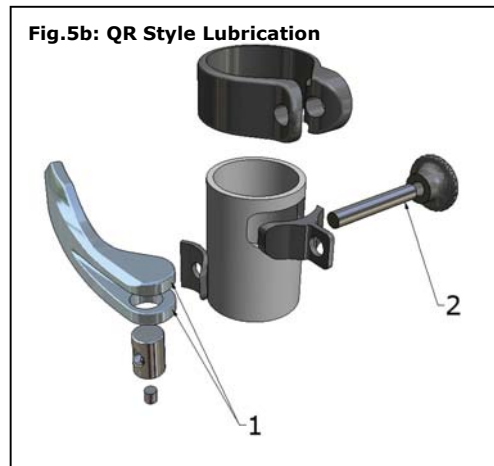

6.0: SERVICING THE REAR SUSPENSION

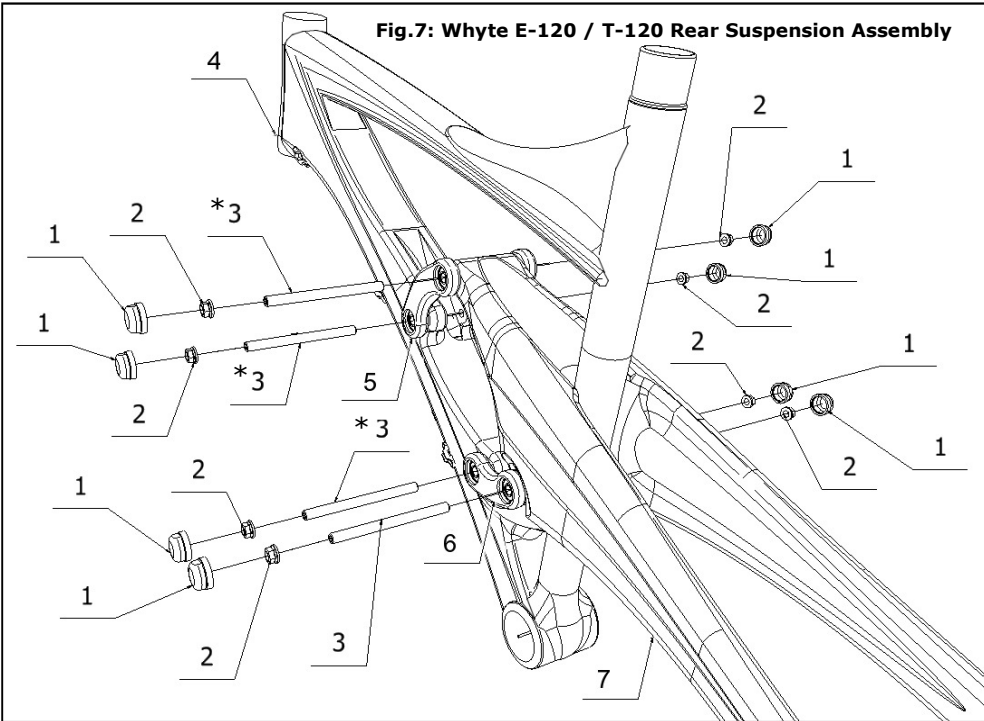

Fig.7: Whyte E-120 / T-120 Rear Suspension Assembly

Item	Description
1	Screw in Bearing Cap (19mm A/F)
2	M8 Aerospace Nut (10mm A/F)
3	M8 x 100mm long Stud ("*3" indicates 90mm long in T-120)
4	E-120 or T-120S Main frame
5	Front 75mm centres Carbon Fibre Link Assembly
6	Rear 50mm centres Carbon Fibre Link Assembly
7	E-120 or T-120S Swinging Arm

Fig.11a: KP Bearing Extraction

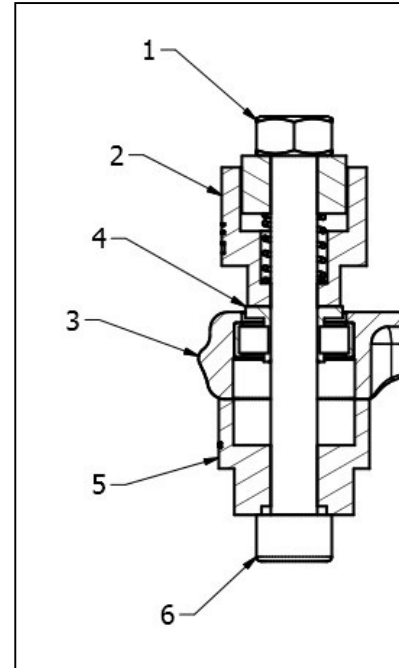
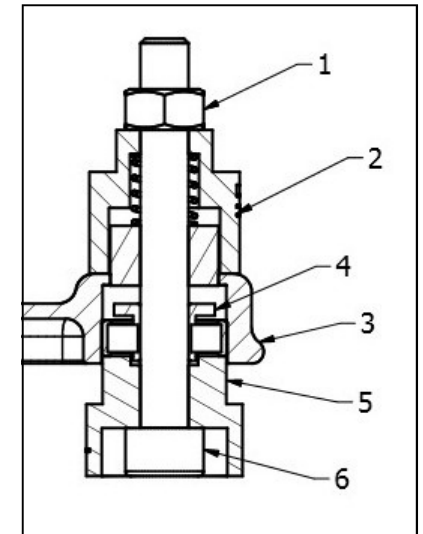

Fig 11b: KP Bearing Insertion



Item:	Description.
1	M8 Nut
2	KP5AX or KP6AX Tool 1
3	Link Body
4	KP5AX or KP6AX Bearing
5	KP5AX or KP6AX Tool 2
6	M8x65mm Socket Head Cap Screw

6.2.2 From the 146

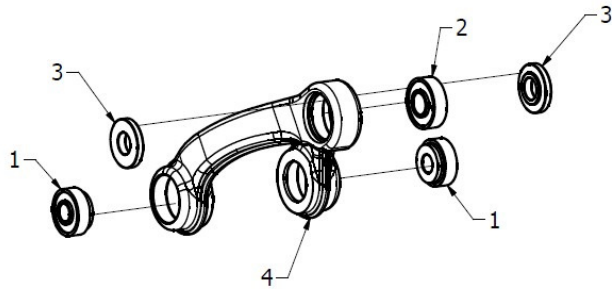
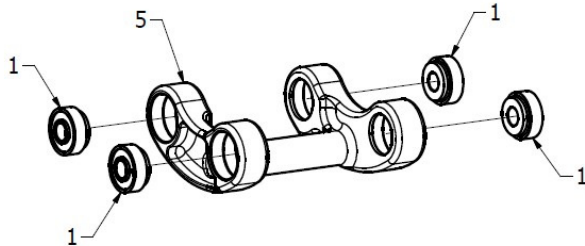
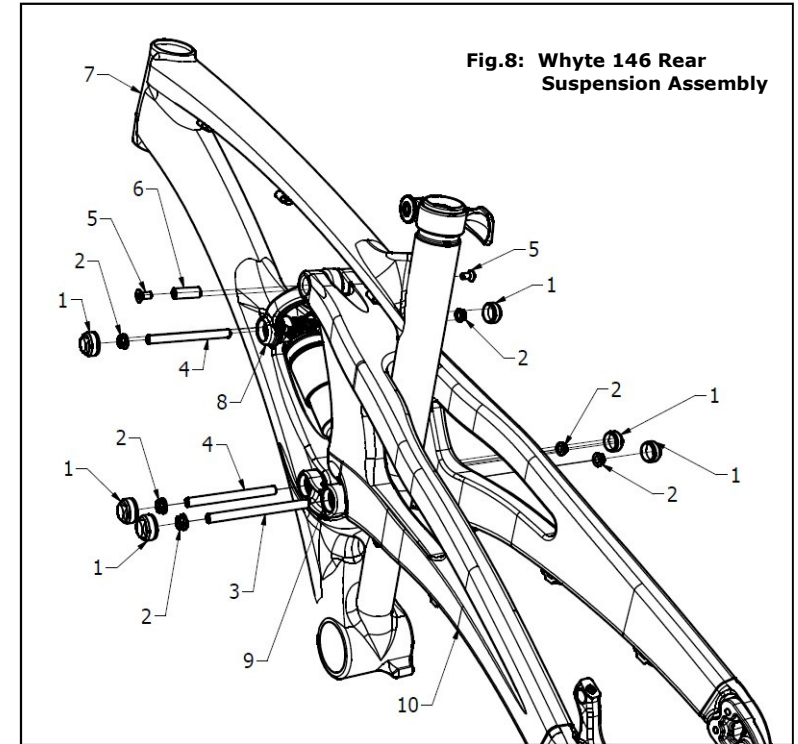

Fig.10: 146 Link Assemblies for front 80mm Y-link (above) and rear 55mm Quad-Link (below)



Item	Description
1	KP5AX bearing
2	KP6AX bearing
3	Outer stepped shield washer
4	Front 80mm "Y" Quad-Link Body
5	Rear 55mm "H" Quad-Link Body



Item	Description
1	Screw in Bearing Cap (19mm A/F)
2	M8 Aerospace Nut (10mm A/F)
3	M8 x 100mm long Stud
4	M8 x 90mm long Stud
5	M6 x 12 long Countersunk Capscrew
6	Ø9.5mm x 25 long Hollow Pin (M6 internal threads)
7	146S Main frame
8	Front 80mm centres Y-Link Assembly
9	Rear 55mm centres H-Link Assembly
10	146S Swinging Arm

6.1: REMOVING THE REAR SHOCK AND SWINGING ARM

Tools Required: 19mm Open-ended, or adjustable spanner
 4mm AF Allen Key
 Medium sized flat-bladed screwdriver
 10mm AF Socket (2 off, 1 being a fitted to a torque wrench)

6.1.1 From the E-120 or T-120

Reference figure 7. To remove the rear damper from the frame, using the 19mm open ended spanner, unscrew the 8 Bearing Caps (1), 4 caps per each link. Next using the 10mm Sockets, undo the M8 Aerospace nuts (2) on the M8 shaft (3 or *3) that passes through the rear link assembly (6) and swinging arm (7). Whichever Aerospace Nut (2) becomes undone first, remove it, and pull the M8 Shaft (3 or *3) out from the other side. The swinging arm (7) can now be rotated out of the rear link assembly (6). In E-120 models made before 2011, be careful to retain all the shield washers that fit into the Quad-Link assemblies, see fig. 8 (note that all models manufactured from 2011 model year onwards, the shield washers are replaced by a flange incorporated into each KP5AX bearing). Next using the 10mm sockets undo the M8 Aerospace nuts (2) on the M8 Shaft (3 or *3) that pass through the front of the Swinging Arm (7). Whichever Aerospace Nut (2) becomes undone first, remove it, and pull the M8 Shaft (3 or *3) out from the other side. You can now lift off the Swinging Arm (7) from the front (5) and rear (6) link assemblies. To remove the links (5 & 6) from the main frame (4) using the 10mm Sockets, undo the M8 Aerospace nuts (2) on the M8 shaft (3 or *3) that passes through the Main Frame (4) and front of the Shock assembly. Again whichever Aerospace Nut (2) becomes undone first, remove it, and pull the M8 Shaft (3 or *3) out from the other side. You can now remove the Shock assembly (not shown) and Front Link Assembly (5) from the main frame (4). To Remove the Rear Link Assembly (6) from the bike, using the 10mm Sockets, undo the M8 Aerospace nuts (2) on the M8 shaft (3 or *3) that passes through the Rear Link Assembly (6) and the Main Frame (7) and remove the M8 shaft (3 or *3) and the Rear Link Assembly (6) from the Main Frame (4). In E-120 models made before 2011, be careful to retain all the shield washers that fit into the Quad-Link assemblies, see fig. 8.

6.1.2 From the 146

Reference figure 8. To remove the rear damper from the frame, using the 19mm open ended spanner, unscrew the 6 Bearing Caps (1), 4 caps in the lower H-link and 2 caps in the upper Y-link. Next using the 10mm Sockets, undo the M8 Aerospace nuts (2) on the M8 shaft (3) that passes through the rear link assembly (9) and swinging arm (10). Whichever Aerospace Nut (2) becomes undone first, remove it, and pull the M8 Shaft (3) out from the other side. The swinging arm (10) can now be rotated out of the rear link assembly (9). Next using the 4mm A/F Allen key undo the M6 countersunk socket screws (5) in the Ø9.5 x 25 long hollow pin (6) that pass through the front of the Swinging Arm (10). Whichever screw (5) becomes undone first, remove it, and push the pin (6) all the way out towards the other side. You can now lift off the Swinging Arm (10) from the front (8) and rear (9) link assemblies. To remove the links (8 & 9) from the main frame (7) using the 10mm Sockets, undo the M8 Aerospace nuts (2) on the M8 shaft (4) that passes through the Main Frame (7) and front of the Shock assembly. Again whichever Aerospace Nut (2) becomes undone first, remove it, and pull the M8 Shaft (4) out from the other side. You can now remove the Shock assembly (not shown) and Front Link Assembly (8) from the main frame (7). To remove the Rear Link Assembly (9) from the bike, using the 10mm Sockets, undo the M8 Aerospace nuts (2) on the M8 shaft (4) that passes through the Rear Link Assembly (9) and the Main Frame (7) and remove the M8 shaft (4) and the Rear Link Assembly (9) from the Main Frame (7).

6.2: STRIPPING AND REASSEMBLING FRONT AND REAR QUAD-LINKS.

6.2.1 From the E-120 or T-120

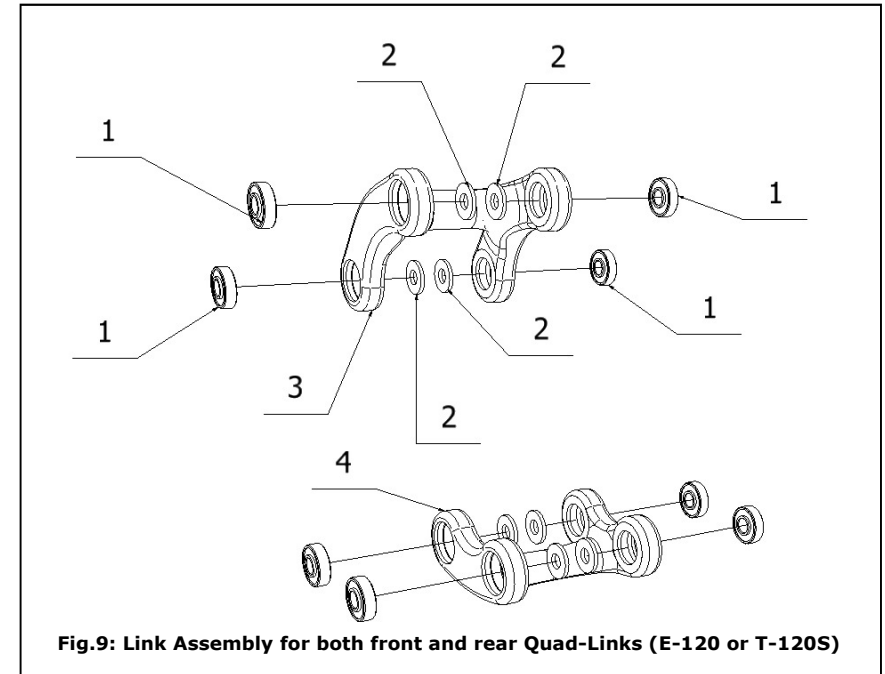

Fig.9: Link Assembly for both front and rear Quad-Links (E-120 or T-120S)

Item	Description
1	KP5AX bearing
2	Middle shield washer (note: only fitted to pre-2011 E-120)
3	Front 75mm Carbon Fibre (E-120) or Alloy (T-120) Quad-Link Body
4	Rear 50mm Carbon Fibre (E-120) or Alloy (T-120) Quad-Link Body