



[www.whytebikes.com](http://www.whytebikes.com) 



[www.whytebikes.com](http://www.whytebikes.com) 

**Whyte E-120 (All Models)  
Service and Instruction Manual  
Edition 2: November 2008**

**8.0: TORQUE SETTINGS**

<b>Rear Quad-Link Suspension:</b>	<b>Nm</b>	<b>lbs.ft</b>
Link Outer Bearing Caps	2.5	1.9
M8 AeroSpace Nuts	18.0	13.3
<b>Rear Big Gripper Dropout</b>		
M5 Through Axle Nuts	7.0	5.0
M6 Half Nut on Catch Stud	7.0	5.0

*Torque explained: If no suitable Torque Wrench is available a Torque of 5 lbf.ft can be obtained by applying a force of 5lb, with a Spring Balance, to the end of a spanner, 1 Foot in length.*

**IMPORTANT:** For all other torque settings, refer to the specific manufacturers information bundled with this manual, or alternatively, refer to the specific manufacturers website for further information.

**9.0: NOTES**

## WHYTE E-120 Service Manual

### **7.1 DISASSEMBLY OF REAR BIG GRIPPER:**

*Tools Required:* 10mm A/F Spanner  
8mm A/F socket with ratchet or T-bar drive (2 off)  
Flat bladed screwdriver  
3mm A/F Allen key  
Pin punch for removing 5mm Roll pin.

Remove Rear wheel from bike by rotating both QR levers anticlockwise (1) to the down position and opening the Dropout Bases (9 & 11). To remove the Big Gripper Bobbins (5) from the rear wheel use the 8mm A/F sockets to loosen and remove the M5 Nuts (3) Remove Washers (4) and Through Stud (7). The Big Gripper Bobbins (5) can now be pulled from the axle ends of the wheel. The Detent Spring (2) retains the QR Levers (1) into the Dropout and so the Detent Spring (2) must be removed first by pulling it vertically downwards. The QR Levers (1) can now be removed from the Dropout. To remove Stud-catch (6) from Dropout Base (9 & 11) remove Lock nut (10) with the 10mm A/F spanner and then turn Stud-catch (6) clockwise using the Flat bladed screwdriver. To remove Dropout Base (9 & 11) support the dropout body and use the Pin Punch to drift out Roll Pin (8)

### **7.2 REASSEMBLY OF REAR BIG GRIPPER:**

*Tools Required:* 10mm A/F Spanner  
8mm A/F socket with ratchet or T-bar drive (2 off)  
Flat bladed screwdriver  
3mm A/F Allen key

This procedure is basically the reverse of the dis-assembly procedure. Refer to the Lubrication section for details of maintenance.

### **7.3 ADJUSTMENT TO THE CLAMPING FORCE ON THE BIG GRIPPER DROPOUT**

*Tools Required:* 10mm A/F Spanner  
Flat bladed screwdriver

This adjustment is made by loosening the Locknut (10) and rotating Stud-catch (6) until the desired force is obtained. With the unit fully assembled and the wheel in its proper position the correct setting is when the QR Lever (1) can easily be rotated to the vertically up position by hand. A slight resistance should only be felt during the last quarter turn as the cam in the Barrel-catch pulls the Stud-catch up to clamp the wheel in position. Ensure that there is not too much force and that the vertically up position can be achieved. With this system a large clamping force is not required as the wheel is well located. If the force is too large then turn the Stud-catch (6) clockwise (when viewed from below) and if there is not enough force turn the Stud-catch (6) anti-clockwise. When the correct setting has been obtained tighten the Lock nut (10)

## Table of Contents

<u>1.0</u>	<u>Introduction</u>
<u>2.0</u>	<u>Whyte E-120 Specifications and Geometry:</u>
2.1	E-120 XT
2.2	E-120 Trail
2.3	E-120 Team
2.4	Superbike
2.5	Geometry
2.5.1	E-120 XT, Trail and Team Geometry
2.5.2	E-120 Superbike Geometry
<u>3.0</u>	<u>Preparations for riding:</u>
3.1	Making Adjustments
3.1.1:	Getta-Grip Seat Clamp
3.1.2:	Cockpit adjustments
3.2	Set up of Fork
3.3	Set up of Rear Damper
3.4	Whyte Big Gripper Dropout System
<u>4.0</u>	<u>Safety.</u>
<u>5.0</u>	<u>Lubrication:</u>
5.1	Getta-Grip Seat Clamp
5.2	Whyte Big Gripper Dropout System
5.3	General E-120 Lubrication
<u>6.0</u>	<u>Servicing the Rear Suspension:</u>
6.1	Removing the Rear Damper and Swinging Arm
6.2	Stripping and Re-assembling Front and Rear Quad-Links
6.2.1	Extraction of KP5AX Bearings
6.2.2	Insertion of KP5AX Bearings
6.2.3	Re-Assembly of Quad-Links
6.3	Re-assembling the Rear Suspension
6.3.1	Correct Orientation of Front and Rear Quad-Links
6.3.2	Re-Assembling the Rear Suspension
<u>7.0</u>	<u>Servicing Whyte Big Gripper Dropout System:</u>
7.1	Disassembly of Rear Big Gripper
7.2	Reassembly of Rear Big Gripper
7.3	Adjustment to Clamping Force of Rear Big Gripper
<u>8.0</u>	<u>Tightening Torque Settings.</u>
<u>9.0</u>	<u>Notes</u>

**7.0: SERVICING WHYTE BIG GRIPPER DROPOUT SYSTEM.**

**1.0: INTRODUCTION**

Thanks for choosing the Whyte E-120. We hope you will enjoy all the benefits its advanced design and engineering will bring to your riding experience.

This manual will guide you through the necessary set-up, safety and maintenance procedures involved in using and servicing your E-120 frameset. But please remember, if you are in any doubt about your ability to correctly and safely service or repair your E-120, do not ride your bike, and get your local Whyte dealer to do the job safely and correctly.

Bundled with this manual, are the respective manufacturers instructions and manuals for the branded parts that go to make up the Whyte E-120 build. Please take time to study both this manual and all the relevant instruction manuals to ensure you have a continually safe and well set-up bike before every ride, and to help you build up a relationship of knowledge between you and your Whyte Dealer.

Happy and safe riding,

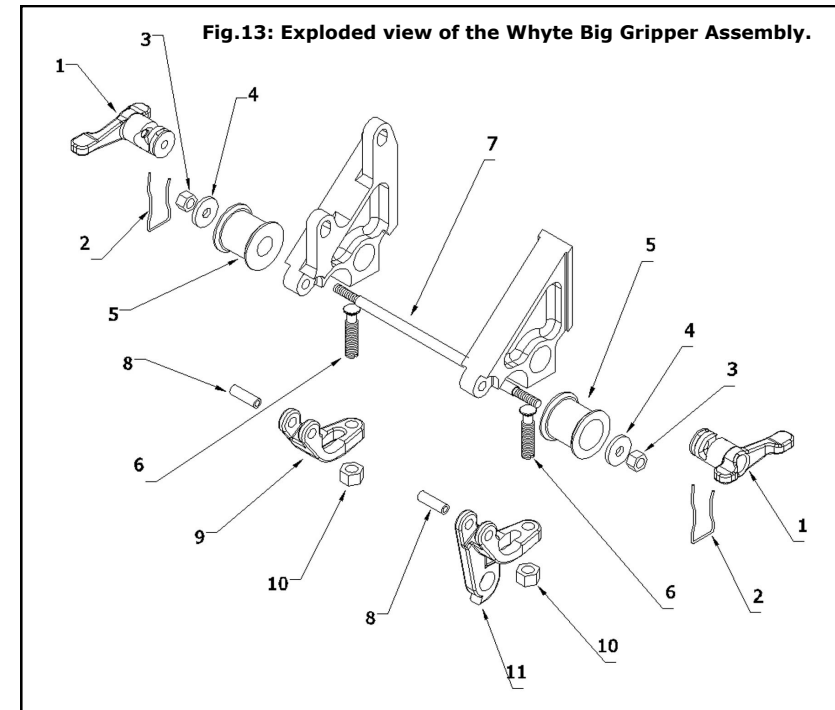

Item	Description
1	Big Gripper QR Lever
2	Detent Spring
3	M5 Nylock Nut
4	Washer
5	Big Gripper Bobbin
6	Catch Stud
7	Through Stud (Rear 170mm)
8	Roll Pin Spirol
9	Dropout Base LH
10	M6 Half Nut
11	Dropout Base RH (Mech Hanger)

it has passed though the other side. Next rotate the Carbon Swinging Arm (7) down to attach it to the rear Quad-Link (6) and the rear of the Rear Shock. Ensure that the Middle Shield Washers (2, Fig.9) in the rear Quad-Link assembly and the Shield Washers in the Bearing Upgrade kit are not pushed out, as you lower the swinging arm into position. Once you have the Carbon Swinging Arm (7) in the correct position, make sure that the rear Quad-Link (6), the Carbon Swinging Arm (7) and the Rear Shock though holes are all concentric with each other, and push through the last remaining M8 Shaft (3). Next re-fit the M8 AeroSpace Nuts (2). **IMPORTANT:** before final tightening of the M8 AeroSpace Nuts (2), it is important to make sure that there is a balanced amounts of thread showing through the M8 AeroSpace Nuts (2) on each side of the Quad-Links. Using the 4mm Allen key in the end of the M8 Shafts (2), and the 10mm spanner, adjust all 4 M8 Shafts (2) accordingly. Refer to Fig.12.

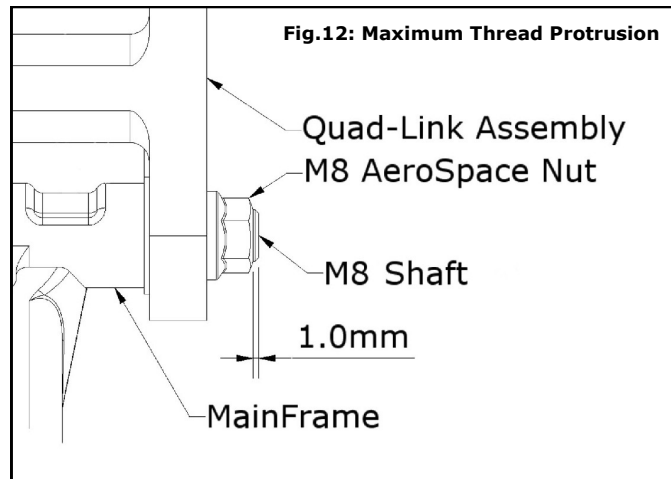

Tighten all M8 AeroSpace Nuts (2) to the recommended settings. (Refer to the Tightening torque settings in Section 8.0) Next make sure that there is still a substantial amount of Molykote 111 Silicon covering all the KP5AX Bearings. Lastly refit the Link Bearing Caps (1) by carefully screwing them into the link body. Take care not to cross thread the fine thread. Wipe off any excess Molykote 111 Silicon from around the links and frame.

**2.0: WHYTE E-120 SPECIFICATIONS AND GEOMETRY**

**2.1: E-120 XT**

Frame	Uni-directional Multi Monocoque Front Triangle, Single Monocoque Rear Swing arm, Carbon Linkages
Fork	Fox F120RL, QR15, 120mm
Shifters	Shimano XT SL-M770
Brake Levers	Avid ELIXIR
Crankset	Shimano XT FC-M770, 44/32/22 with Hollowtech II Arms and Carbon Middle Chain Ring
Chain	Shimano HG-73
Front Mech	Shimano XT, FD-M770
Rear Mech	Shimano XT, Shadow, RD-M772
Cassette	Shimano CS-M770 11-34
Rear Hub	Shimano XT Wheelset WH-M775 with Centre-Lock Disk Rotors
Front Hub	Shimano XT Wheelset WH-M778 QR15 with Centre-Lock Disk Rotors
BB	Shimano XT Big Pipe Billet Integrated with Crankset
Brakes	Avid ELIXIR with centre-lock Rotors, 160mm Front and Rear
Rims	Shimano XT Wheelset WH-M775/8
Spokes	Shimano XT Wheelset WH-M775/8
Tyres	Continental Mountain King 26 X 2.2" with Kevlar Bead
Headset	FSA Special Whyte Integrated headset, with 1/18" top and 1 1/4" Lower Sealed Cartridge Bearings
Seatpost	Thomson In-Line, 30.9mm x 410mm
Saddle	Fi'zi:k Gobi XM with Mag Rails
Bar	Easton Monkeylite XC Low Rise, 31.8mm OD, 685mm Long
Stem	Easton EA50, 31.8mm Bar Clamp, 70mm XS, 80mm S, 90mm M, 90mm L
Grips	Whyte Semi Lock-on's
Rear Shock	Fox Float RP2, with Rebound Adjuster and 2 Position ProPedal Lever. Whyte Designs Cartridge Bearing Shock Bushings

**2.2: E-120 Trail**

Frame	Uni-directional Multi Monoque front triangle, single monoque Rear Swing arm, Carbon Linkages
Fork	RockShox Reba Race 120mm with Maxle Light 20mm, Remote Push-lock Motion Control Damping, Adjustable Rebound
Shifters	SRAM X-0
Brake Levers	ELIXIR Carbon
Crankset	Shimano XT FC-M770, 44/32/22 with Hollowtech II Arms and Carbon Middle Chain Ring
Chain	SRAM PC-971
Front Mech	Shimano XT, FD-M770
Rear Mech	SRAM X-0 Long Cage
Cassette	SRAM PG-990 11-34
Rear Hub	Hope II Pro Disc Hub 32 Hole
Front Hub	Hope II Pro Disc Hub 20mm through Axle, 32 Hole
BB	Shimano XT Big Pipe Billet Integrated with Crankset
Brakes	ELIXIR Carbons, with Centre-lock Rotors, 180 Front and 160 Rear Rotors
Rims	Mavic XC-717, 32 Hole, Black
Spokes	DT Competition Butted 1.8-1.6-1.8mm, Black Stainless with Brass Nipples
Tyres	Panaracer Cinder 26 X 2.25" with Kevlar Bead
Headset	FSA Special Whyte Integrated headset, with 1/18" top and 1 1/4" lower Sealed Cartridge Bearings
Seatpost	Thomson In-line, 30.9 X 410mm
Saddle	Fi'zi:k Gobi XM with Mag Rails
Bar	Easton Monkeylite XC Low Rise, 31.8mm OD, 685mm Wide
Stem	Thomson X4, 31.8mm Bar Clamp, 70mm XS & S, 90mm M, 100 L
Grips	Whyte Semi Lock-on's
Rear Shock	Fox Float RP23, with Rebound Adjuster adjustable DOHC ProPedal. Whyte Designs Cartridge Bearing Shock Bushings

**6.3.2: REASSEMBLING THE REAR SUSPENSION**

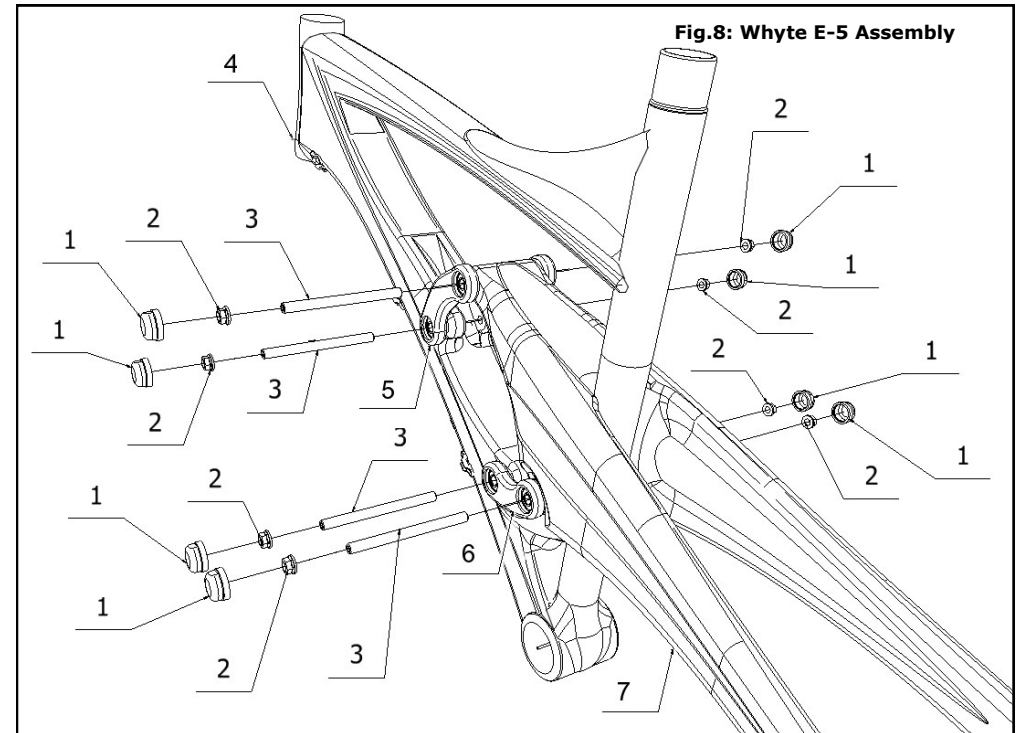

The re-assembly of the rear suspension is basically the reverse of the dis-assembly procedure. Starting with the rear 50mm Quad Link (6) Ensure the Quad-Link (6) is correctly orientated (see fig 10 and 11) and pass an M8 Shaft (3) through the Quad-Link (6) and Main Frame (4). Next take the Rear Shock (Not Shown) and assemble the front mount of the Rear Shock using SKF LG/AF anti fret paste on the contacting surfaces, into the forward shock mount of the Mainframe (4). **IMPORTANT.** Ensure the damper is the correct way up, with any dials and levers facing upwards. Assemble the front Quad-Link (5) onto the Mainframe (4), and pass an M8 Shaft (3) through the front Quad-Link (5), the Mainframe (4) and through the front of the Rear Shock until the M8 Shaft (3) is showing out the other side of the front Quad-Link(5). You should now have both front and rear Quad-Links assembled onto the Mainframe (4), with the Rear Shock in position. Next, lower the Carbon Swinging Arm (7) onto the rear suspension assembly and position the Carbon Swinging Arm (7) onto the front Quad-Link (5) first. Pass an M8 Shaft (3) through the front Quad-Link (5) and Carbon Swinging Arm (7) until

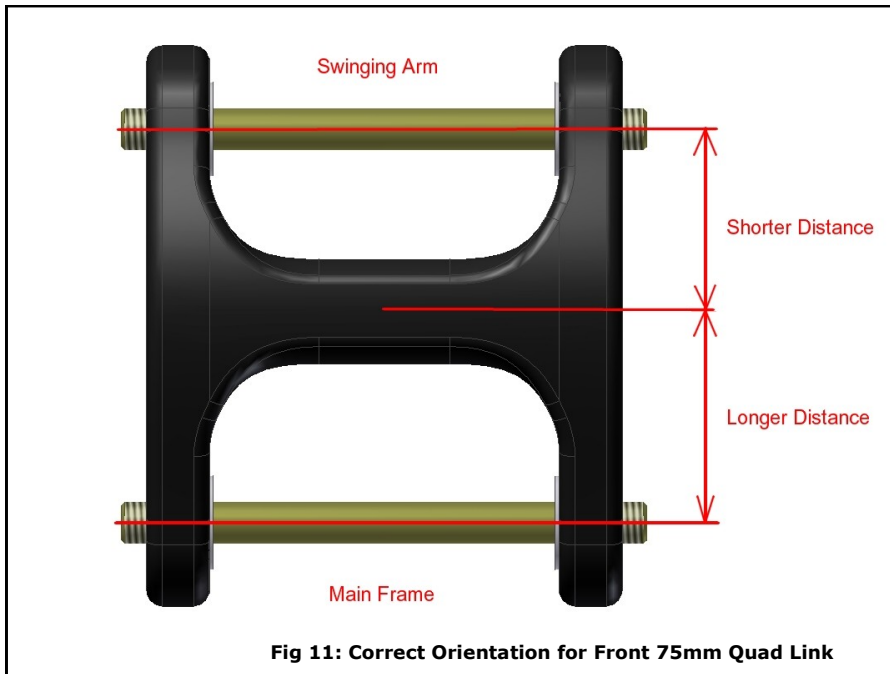

**Fig 11: Correct Orientation for Front 75mm Quad Link**

**Fig.12: Front Quad-Link Orientation.**

Ensure that upon assembling the Front Quad-Link to the mainframe, that the link cross bridge is orientated as shown in Fig.11.

**2.3: E-120 Team**

Frame	Uni-directional Multi Monocoque Front Triangle, Single Monocoque Rear Swing Arm, Carbon Linkages
Fork	Fox F120RLC QR15, 120mm, Titanium
Shifters	Shimano XTR SL-M970
Brake Levers	Hope Carbon
Crankset	Shimano XTR FC-M970, 44/32/22 with Hollowtech II Arms and Carbon Middle Chain Ring
Chain	Shimano CN-7701
Front Mech	Shimano XTR FD-M970
Rear Mech	Shimano XTR, Shadow Carbon RD-M972
Cassette	Shimano CS-M970 11-32
Rear Hub	Hope X-C Pro III Wheelset, With 15QR and 3 Bolt Rotor Attachment
Front Hub	Hope X-C Pro III Wheelset, With 3 Bolt Rotor Attachment
BB	Hope Technology, External Bearing Bottom Bracket
Brakes	Hope Mini Pro, 1pcs Calipers and Ti Hardware, 160mm Rotors
Rims	Hope Pro III Wheelset using DT 4.2D Rims
Spokes	Hope X-C Pro III Wheelset, With 3 Bolt Rotor Attachment
Tyres	Maxxis High-Roller 26 X 2.1" with Kevlar Bead
Headset	FSA Special Whyte Integrated headset, with 1/18" Top and 1 1/4" Lower Sealed Cartridge Bearings
Seatpost	Easton EC90, Zero Layback, 30.9mm x 400mm
Saddle	Fi'zi:k Gobi XM with k:iium Rails
Bar	Easton Monkeylite XC Low Rise, 31.8mm OD, 685mm Long
Stem	Easton EA90 31.8mm Bar Clamp, 70mm XS & S, 90mm M & L
Grips	Whyte Semi Lock-on's
Rear Shock	Fox Float RP23, with Rebound Adjustment and Adjustable DOHC ProPedal. Whyte Designs Cartridge Bearing Shock Bushings

**2.4: E-120 Superbike**

Frame	Uni-directional Multi Monocoque Front Triangle, Single Monocoque Rear Swing arm, Carbon Linkages
Fork	DT Swiss XMC 130 QR15, 130mm travel, Carbon Lowers. Rebound and Compression Adjust.
Shifters	Shimano XTR SL-M970
Brake Levers	Formula Carbon
Crankset	Shimano XTR FC-M970, 44/32/22 with Hollowtech II Arms and Carbon Middle Chain Ring
Chain	Shimano CN-7701
Front Mech	Shimano XTR FD-M970
Rear Mech	Shimano XTR, Shadow Carbon RD-M972
Cassette	Shimano CS-M970 11-32
Rear Hub	DT Swiss 240, Centre-Lock
Front Hub	DT Swiss 240 15QR, Centre-Lock
BB	Hope Technology, External Bearing Bottom Bracket
Brakes	Formula R1, Carbon, Floating Rotors, 180 Front and 160 Rear Rotors
Rims	DT Swiss XCR 330 Carbon, 32 Hole
Spokes	DT Swiss Aerolite with Red Alloy Nipples
Tyres	Maxxis High-Roller 26 X 2.1" with Kevlar Bead
Headset	FSA Special Whyte Integrated Headset, with 1/18" Top and 1 1/4" Lower Sealed Cartridge Bearings
Seatpost	Easton EC90, Zero Layback, 30.9mm x 400mm
Saddle	Fi'zi:k Gobi XM with k:iium Rails
Bar	Easton Monkeylite XC Low Rise, 31.8mm OD, 685mm Wide
Stem	Easton EA90 31.8mm Bar Clamp, 70mm XS & S, 90mm M & L
Grips	Whyte Semi Lock-on's
Rear Shock	DT Swiss XR Carbon, with Lock-Out and Rebound Adjust

**6.3: REASSEMBLING THE REAR SUSPENSION.**

**6.3.1: CORRECT ORIENTATION OF FRONT AND REAR QUAD-LINKS.**

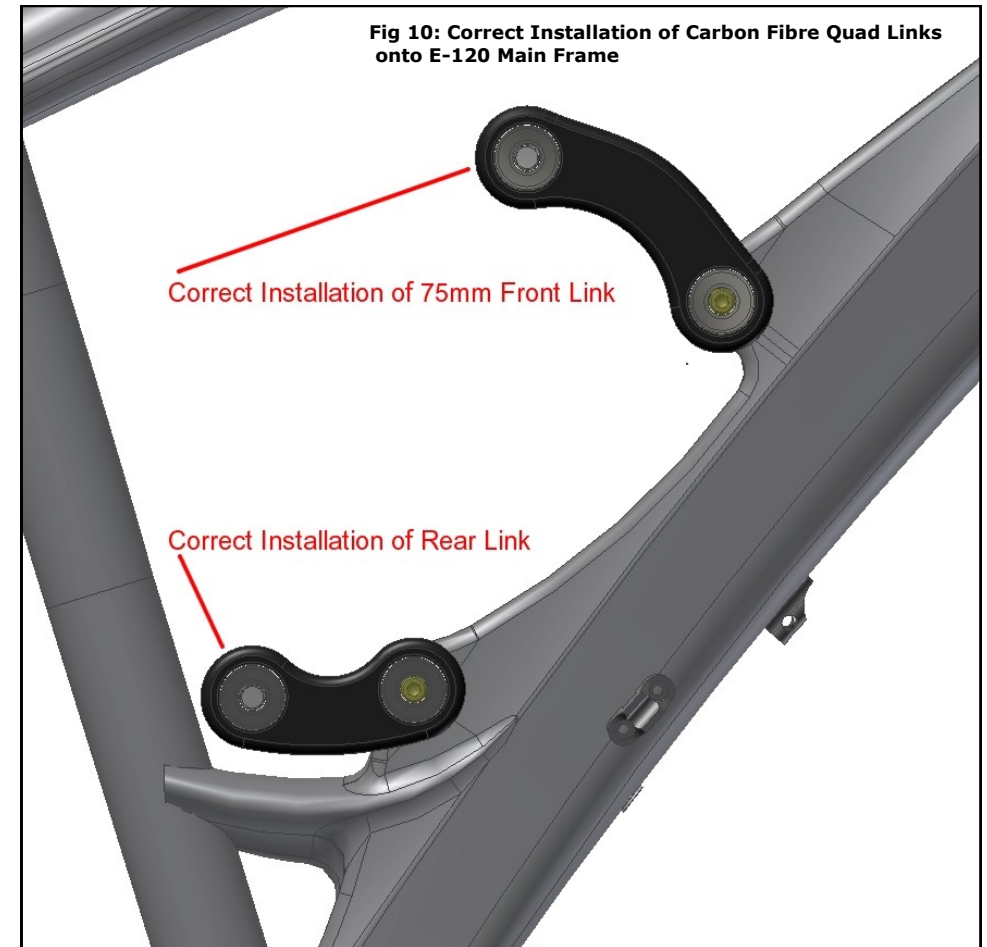

**Fig.11: Carbon Fibre Quad-Link Orientation: Correct Assembly**  
Ensure that upon assembling the Quad-Links to the mainframe, that the links are orientated as shown in Fig.10

**6.2.1: EXTRACTION OF KP5AX BEARINGS**

*Tools required:* Whyte KP5AX bearing press tool.  
6mm AF Allen Key  
10mm AF Spanner.

To remove the KP5AX Bearings (5) from the Link Body (4). Assemble the parts as shown in Fig 10a. Using the 6mm Allen Key and 10mm spanner, tighten the assembly together until the KP5AX bearing(5) is pressed out of the Link Body (4). Repeat on all 7 other KP5AX bearings. To re-insert the KP5AX bearings into the Link Body

**6.2.2: INSERTION OF KP5AX BEARINGS**

*Tools required:* Whyte KP5AX bearing press tool.  
6mm AF Allen Key  
10mm AF Spanner  
Loctite 638

Before re-assembling both front and rear link assemblies, make sure all the components are clean from dirt and have been thoroughly de-greased. To press the KP5AX bearings (5) into the Link Body (4) apply a small amount of Loctite 638 to the outside diameter of the KP5AX bearing and to the inside Bearing bore of the Link Body (4). Next assembly the components as illustrated in Fig.9b. It is very important to make sure the KP5AX (5) bearing and Bearing Insertion tool 1 (3) are squarely seated against the Link Body (4). With great care, slowly tighten the M8 Socket head cap screw (7) with the 6mm Allen key and 10mm Spanner until you can see the KP5AX bearing (5) being pressed squarely into the Link Body (4). Once the KP5AX bearing is fully seated an you can no longer tighten the M8 Socket Head Cap Screw further, undo the nut and bolt and remove any excess Loctite from around the KP5AX Bearing. Repeat for the remaining 7 KP5AX Bearings.

**6.2.3: REASSEMBLY OF QUAD-LINKS**

*Tools required:* Molykote Silicon 111

Before re-assembling the Middle Shield Washer Components (2 see Fig.8), apply a good quantity of Molykote 111 Silicon on top of the KP5AX Bearings. The Molykote Silicon should completely cover each bearing and be applied on both sides of each bearing as it is assembled into the Link Body. Next assemble the Shield Washer Components (2 see Fig.8), If you have applied enough Molykote 111 Silicon, it should spread from under the Shield Washer component as they are positioned. Wipe this excess Silicon away from around the Shield Washer Components.

**APPLICATION OF SKF LG/AF ANTI-FRET PASTE**

**Once the Links has been assembled correctly, SKF LGAF 3 Compound *must* be applied to all outside faces of the Middle Shield Washer Components (2 see Fig.8), that contact the Main Frame and Swinging Arm. It is additionally recommended to apply SKF LGAF 3 compound to the link contact surfaces on the Main Frame and Swinging Arm.**

**2.5: GEOMETRY**

**2.5.1: E-120 XT, Trail and Team Geometry.**

**Fig.1: E-120 Geometry**

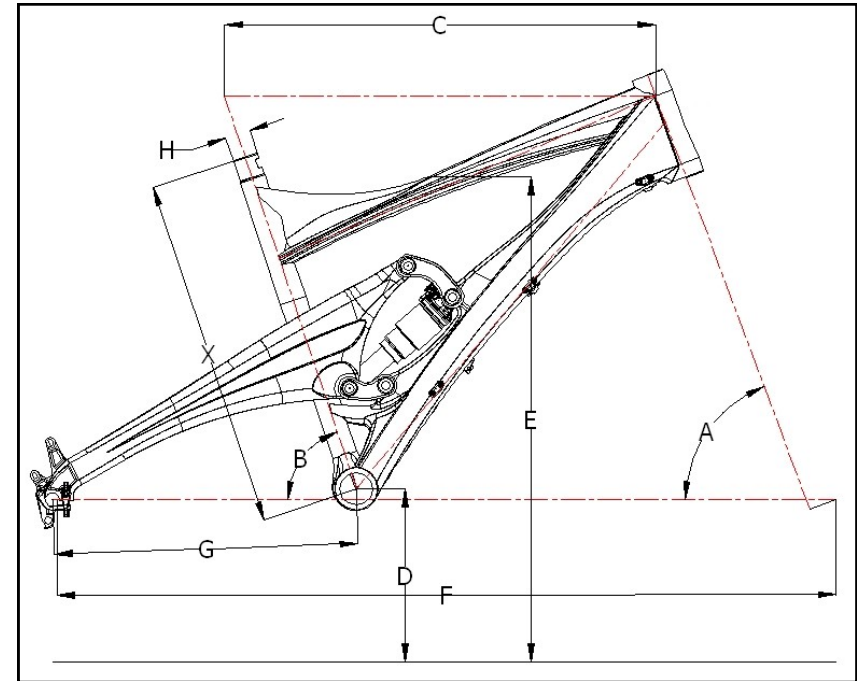

	X-Small	Small	Medium	Large	X
Head Angle	69.6°	69.6°	69.6°	69.6°	A
Seat Angle	71.6°	71.6°	71.6°	71.6°	B
Top Tube	571.9mm	583.5mm	596.2mm	610.3mm	C
BB Height	345.44mm	345.44mm	345.44mm	345.44mm	D
Stand Over	719.3mm	741.9mm	754mm	780.6mm	E
Wheel Base	1058.4mm	1070.7mm	1083.8mm	1098.8mm	F
Chain Stay	420mm	420mm	420mm	420mm	G
Seat Post	30.9mm	30.9mm	30.9mm	30.9mm	H

Note:

Geometry shown here is 'Showroom' i.e. without rider. 'With Sag' geometry is with rider after correct sag is set at front and rear. Please refer to suspension set up for information on how to achieve the correct sag of the fork and rear damper.

**2.5: GEOMETRY**  
**2.5.2: E-120 Superbike**

	X-Small	Small	Medium	Large	X
Head Angle	68.7°	68.7°	68.7°	68.7°	A
Seat Angle	70.6°	70.6°	70.6°	70.6°	B
Top Tube	574.8mm	586.5mm	599.3mm	613.3mm	C
BB Height	350mm	350mm	350mm	350mm	D
Stand Over	734.1mm	748.1mm	760.2mm	786.5mm	E
Wheel Base	1064.5mm	1076.7mm	1090.1mm	1104.8mm	F
Chain Stay	420mm	420mm	420mm	420mm	G
Seat Post	30.9mm	30.9mm	30.9mm	30.9mm	H

Note:

Geometry shown here is 'Showroom' i.e. without rider. 'With Sag' geometry is with rider after correct sag is set at front and rear. Please refer to suspension set up for information on how to achieve the correct sag of the fork and rear damper.

**Fig.9a: KP5AX Bearing Extraction**

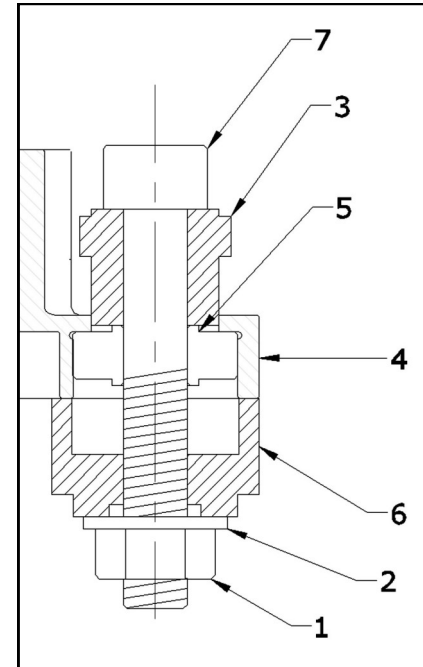

**Fig 9b: KP5AX Bearing Insertion**

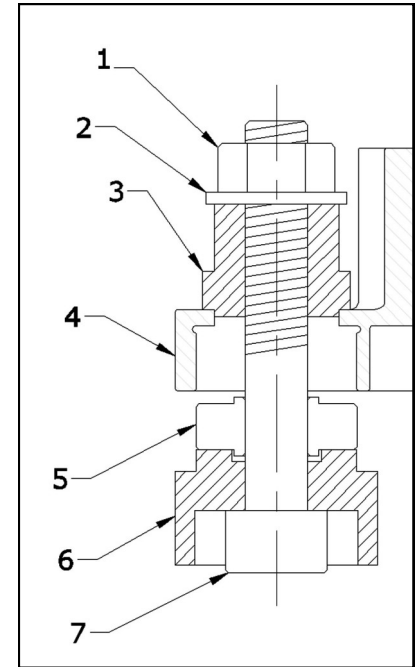

Item:	Description.
1	M8 Nut
2	M8 Washer
3	KP5AX Tool 1
4	Link Body
5	KP5AX Bearing
6	KP5AX Tool 2
7	M8x50mm Socket Head Cap Screw

Bearing Caps (1) 4 per link. Next using the 10mm Sockets, undo the M8 Aerospace nuts (2) on the M8 shaft (3) that passes through the rear link assembly (6) and swinging arm (7). Whichever Aerospace Nut (2) becomes undone first, remove it, and pull the M8 Shaft (3) out from the other side. The swinging arm (7) can now be rotated out of the rear link assembly (6). Take care to retain the spacers that fit into the links. Next using the 10mm sockets undo the M8 Aerospace nuts (2) on the M8 Shaft (3) that pass through the front of the Swinging Arm (7). Whichever Aerospace Nut (2) becomes undone first, remove it, and pull the M8 Shaft (3) out from the other side. You can now lift off the Swinging Arm (7) from the front (5) and rear (6) link assemblies. To remove the links from the main frame (4) using the 10mm Sockets, undo the M8 Aerospace nuts (2) on the M8 shaft (3) that passes through the Main Frame (4) and front of the Shock assembly. Again whichever Aerospace Nut (2) becomes undone first, remove it, and pull the M8 Shaft (3) out from the other side. You can now remove the Shock assembly (not shown) and Front Link Assembly (5) from the main frame (4). To Remove the Rear Link Assembly (6) from the bike, using the 10mm Sockets, undo the M8 Aerospace nuts (2) on the M8 shaft (3) that passes through the Rear Link Assembly (6) and the Main Frame (7) and remove the M8 shaft (3) and the Rear Link Assembly (6) from the Main Frame (4). Be careful to retain all the spacers that fit into the Quad-Link assemblies.

**6.2: STRIPPING AND REASSEMBLING FRONT AND REAR QUAD-LINKS.**

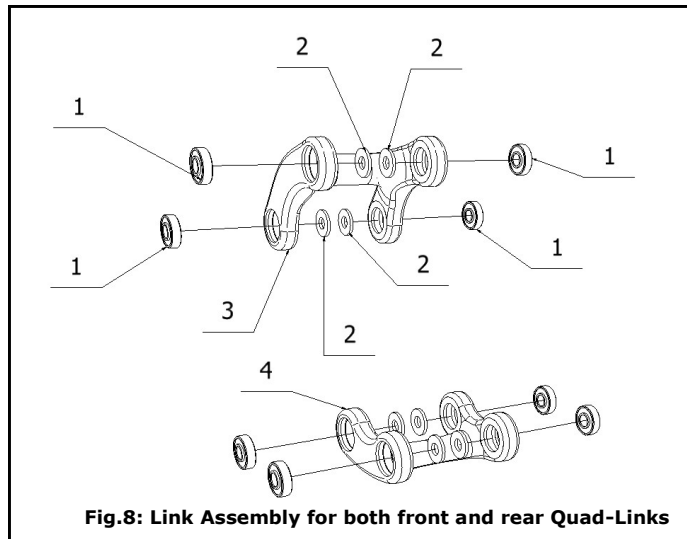

Item	Description
1	KP5AX bearing
2	Middle shield washer
2	Front 75mm Carbon Fibre Quad-Link Body
3	Rear 50mm Carbon Fibre Quad-Link Body

**3.0: PREPARATIONS FOR RIDING**

**3.1: MAKING ADJUSTMENTS**

**3.1.1: WHYTE GETTA-GRIP SEAT CLAMP SADDLE HEIGHT ADJUSTMENT**

The Getta Grip seat clamp design is present on all models of Whyte E-120. It is a patented design to allow adjustment of the saddle height by either the use of a QR Lever, or bolt-up method. The E-120 features a QR type adjustment, but this manual covers both styles of clamp design.

Item:	Description
1	E-120 Seat Clamp Band
2	T-Pad
3	E-120 Main Frame
4	Barrel Nut
5	M6 x 30mm Fastener
6	M6 Washer

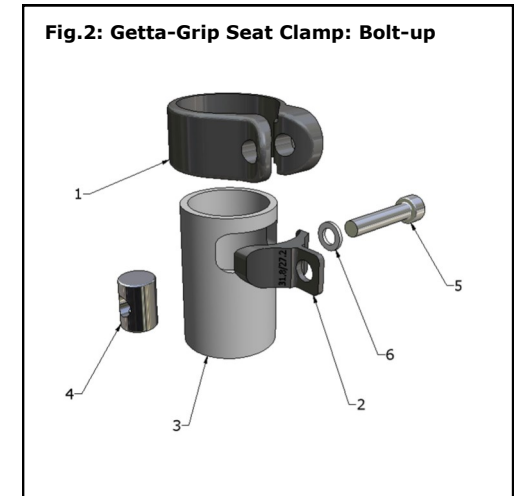

**Bolt-up Type: Fig.2**

Tools Required: 5mm Allen Key

(Note, refer to the seat-pin manufacturers instructions in conjunction with these notes). To adjust the seat height, using the 5mm Allen key, undo the M6 bolt (5) just enough to allow the seat-pin to slide freely up and down. Set the height to the desired level, and re-tighten the M6 bolt (5) with the 5mm Allen Key just enough so as to prevent the seat-pin from slipping down and twisting.

Item	Description
1	QR Lever Cam Grub Screw
2	QR Lever Cam
3	Whyte QR Lever
4	Plastic Shim
5	E-120 Main Frame
6	E-120 Seat Clamp Band
7	QR Adjuster Bobbin
8	QR Shaft
9	T-Pad

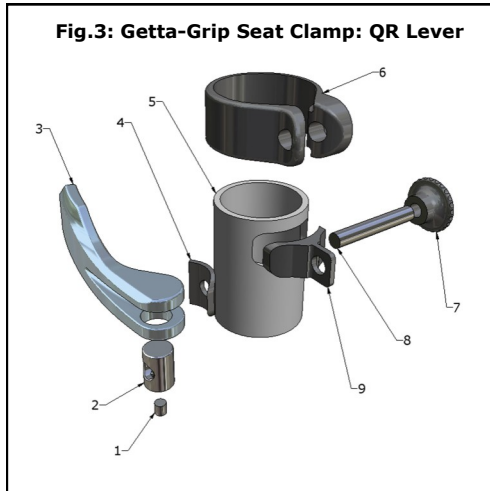

**QR Lever Type: Fig.3**

No tools required.

(Note, refer to the seat-pin manufacturers instructions in conjunction with these notes).

To Adjust the seat height with the QR Lever assembly fitted, simply undo the QR Lever (4) from the Closed position to the Open position. Next adjust the height of the Seat Pin to the desired level, and close the QR lever (4) to the from the Open position to the Closed position. The QR closing force can be adjusted by turning the QR Adjuster Bobbin (8) clockwise or anti-clockwise before closing the QR Lever (4).

**3.1.2: WHYTE E-120 XT, Trail and Team COCKPIT ADJUSTMENTS**

Please refer to the specification chart and from there, the relevant manufacturers instructions to adjust the cockpit components before riding your E-120. This includes information on the Minimum insertion depth of the Seat Post in the frame.

**6.0: SERVICING THE REAR SUSPENSION**

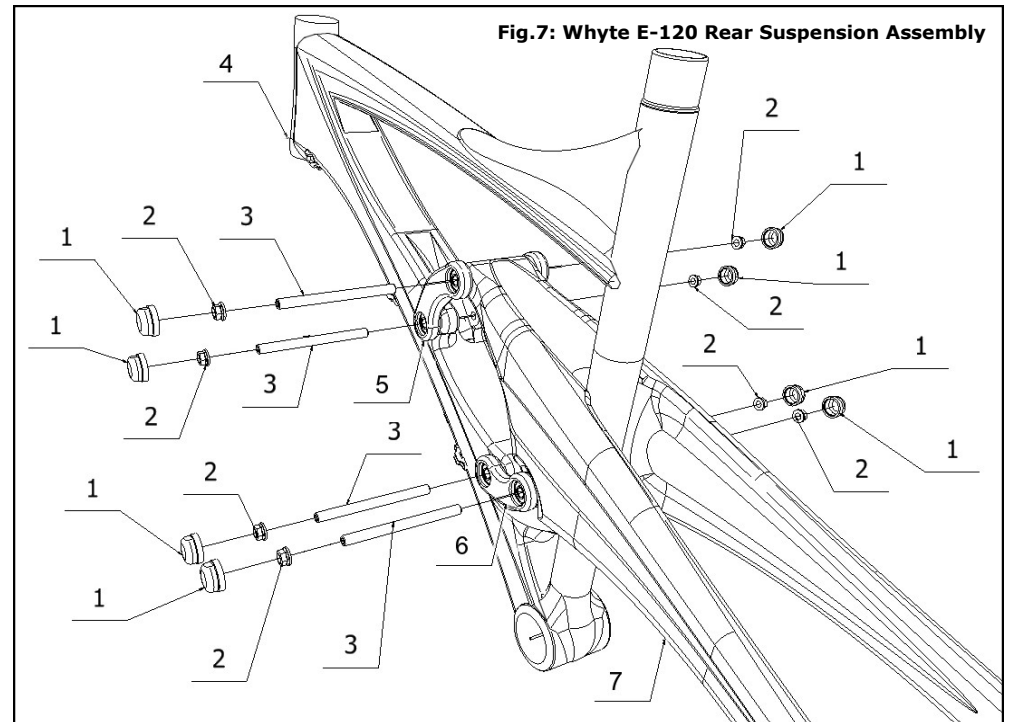

Item	Description
1	Screw in Bearing Cap (19mm A/F)
2	M8 Aerospace Nut (10mm A/F)
3	M8 x 100mm Stud
4	E-120 Main frame
5	Front 75mm Carbon Fibre Link Assembly
6	Rear 50mm Carbon Fibre Link Assembly
7	Swinging Arm

**6.1: REMOVING THE REAR SHOCK AND SWINGING ARM**

Tools Required: 19mm Open-ended, or adjustable spanner  
4mm AF Allen Key  
10mm AF Socket (2 off, 1 being a torque wrench)

To remove the rear damper from the frame, using the 19mm open ended spanner, unscrew the 8

**5.2: WHYTE BIG GRIPPER DROPOUT SYSTEM**

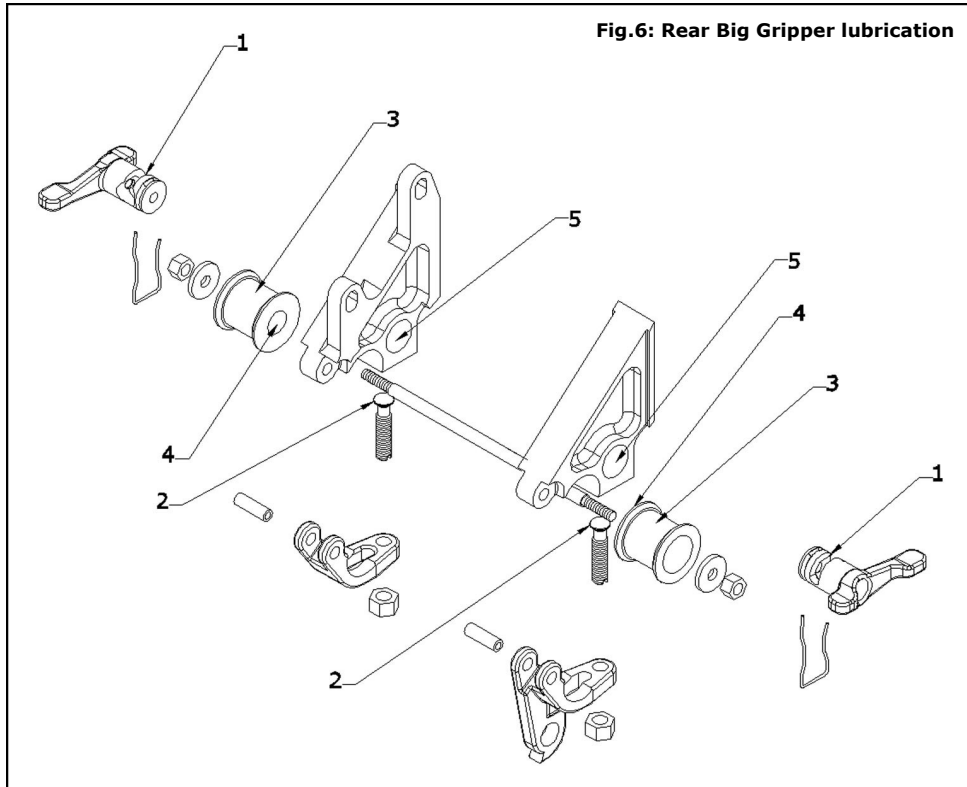

Point	Description	Lubricant	Lubrication Interval
1	QR Lever (Shaft Only)	Castrol LM or equivalent	Once a Month
2	Catch Stud (Head Only)	Castrol LM or equivalent	Once a Month
3	Bobbin Outer Contact Surface	SKF Anti Fret Paste	Once a Month
4	Bobbin Inner Contact Surface	SKF Anti Fret Paste	Once a Month
5	Dropout Inner bore	Castrol LM or equivalent	Once a Month

**5.3: GENERAL E-5 LUBRICATION**

For the correct lubrication regime and maintenance of all parts on both the Whyte E-5 Works and E-5 XT models, please refer to the specific component manufacturers detailed instructions bundled with this manual or for further information visit the specific manufacturers website.

**3.2: SET UP OF FORK**

*Tools Required: Good Quality Shock Pump.*

The front suspension fork fitted to your Whyte E-120 will be pre-set with the standard settings. Before riding, you may need to adjust these setting. First is the Sag setting on the fork. This is to ensure the forks are set-up correctly for your own body weight, so the fork will perform as intended.

To set Sag on the front fork, you need to measure the amount the fork compresses when you sit on the bike in the normal riding position. We recommend for the best synergy between front and rear suspension systems on the E-120 to run approximately 20mm (16%) Sag on the front fork. To achieve this you will need to adjust the air spring pressure inside the fork.

Refer to the specification tables in this manual, and then to the relevant fork manufacturers set up instructions to find how to adjust the air spring pressure in the fork. Using a shock pump, either add or remove air until Sag is correctly set.

Please note that for the detailed instructions for servicing and all matters relating to the forks fitted to your E-120, please refer to the manufacturers instructions.

Rebound Damping adjustment:

This adjustment fine-tunes the speed at which the wheel returns to its normal ride height after hitting a bump. Refer to the relevant manufacturers instructions to find out how to adjust the rebound damping. To demonstrate the effect of this function, turn the adjuster to its slowest setting. Press down on the handlebars to compress the forks, then release the load. The suspension recovers very slowly to its original position.

Repeat the above with the adjuster turned to the fastest setting and the difference will be seen immediately the load is released. We recommend the optimum setting is to adjust the re-bounce damping to be as slow as possible, but not so slow that the normal ride height is not recovered. On very rough terrain, if the bike becomes progressively lower as more bumps are hit then the re-bounce damping is set too slow. On the other hand if the bike feels choppy and not plush then the re-bounce damping is too fast. A bit of trial and error is needed to get the exact setting.

**IMPORTANT SAFETY NOTE:** Always stop riding when making adjustments of any kind to the bicycle!

**3.3: SET UP OF REAR DAMPER**

*Tools Required: Good Quality Shock Pump.*

The Whyte E-120 range is fitted with Air Spring rear shocks. This means the air pressure in the shock determines the spring rate. The correct 'sag' can be found using the sliding 'o' ring fitted to the shaft of the shock piston. Slide the 'o' ring against the shock body. Then gently sit on the bike in your normal riding position. Carefully dismount and measure the distance the 'o' ring has moved away from the shock body.

The optimum distance for the E-120 QUAD-Link system is 14mm displacement from the 'o' ring back up to the shock body. If there is less than 14mm fit a shock pump and release air pressure. Conversely if there is greater than 14mm of travel, fit the shock pump and increase air pressure. Repeat the 'sag' test until the 14mm displacement is achieved.

Rear Suspension Set-up - Rebound Damping:

When the damper unit is being compressed, this is known as the compression stroke. As the suspension unit recovers from compression back towards its full length, this is called the re-bound stroke. All the shocks fitted as standard to the Whyte E-120 bikes have factory set compression damping, and manually adjustable rebound damping.

Rebound Damping Adjustment:

This adjustment fine-tunes the speed at which the rear wheel returns to its normal ride height after hitting a bump. Please refer to the relevant Shock manufacturers technical information to find out how to adjust the Shock. To demonstrate the effect of this, turn the adjuster to its slowest setting. Press down on the saddle to compress the suspension, then release the load. The suspension recovers very slowly to its original position.

Repeat the above with the adjuster turned to the fastest setting and the difference will be seen immediately the load is released. We recommend the optimum setting is to adjust the re-bound damping to be as slow as possible, but not so slow that the normal ride height is not recovered. On very rough terrain, if the rear of the bike becomes progressively lower as more bumps are hit then the re-bound damping is set too slow. On the other hand if the bike feels choppy and not plush then the re-bound damping is too fast. A bit of trial and error is needed to get the exact setting. **IMPORTANT SAFETY NOTE:** Always stop riding when making adjustments of any kind to the bicycle!

Platform Damping Adjustment.

The rear Shock fitted to the Whyte E-120 may have a facility to adjust the slow speed compression damping. Please refer to the relevant shock manufactures technical information to learn how to adjust these features. Please note, that the Whyte E-120 suspension system has been designed not to rely on excessive low speed compression damping to obtain efficient pedalling performance, and turning on too much low speed damping on the Shock will compromise the suspensions sensitivity to small bump absorption and traction.

**5.0: LUBRICATION**

**5.1: GETTA-GRIP SEAT CLAMP**

**5.1.1: BOLT-UP**

Point	Description	Lubricant	Lubrication Interval
1	M6 x 30mm Fastener	Castrol LM or equivalent	Once a Month



**5.1.2: QR STYLE**

Point	Description	Lubricant	Lubrication Interval
1	Whyte QR Lever Cam Surface	Castrol LM or equivalent	After Every Ride
2	M6 QR Shaft	Castrol LM or equivalent	Once a Month

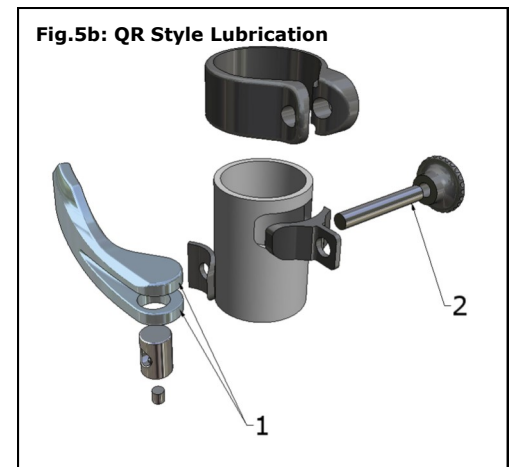

**After Every Ride:**

- **Post-Ride cleaning:** We strongly recommend cleaning your bike after every ride. This provides you with the best opportunity of a close and systematic inspection of almost every component, for damage and wear on a ride by ride basis.
- **Lubrication:** Directly after cleaning your bike after a ride, is the best time to carry out the lubrication regime for the various components as outlined in this manual, and in the respective component manufactures technical information.

**Before every ride: Pre-ride safety check.**

- **Frameset Components:** We recommend that before every ride you visually inspect the mainframe swinging arm and associated components for signs of damage or excessive wear due to hard use.
- **Brakes:** Check the Disc and Brake pads for wear and performance degradation, and the hydraulic hoses for damage, in accordance with the specific recommendations in the relevant component makers instruction manual bundled with this manual.
- **Wheels:** Check that both wheels are securely attached to the bike, and the respective dropout systems are correctly adjusted. Check the condition of both wheels, and look for cracks or large dents in the aluminium Rim, and check for loose or broken spokes and/or spoke nipples, and wheels out of alignment in line with the specific recommendations in the relevant instruction manual bundled with this manual.
- **Lubrication:** Check all parts have been lubricated in accordance with the specific component makers instruction manual.
- **Gear Shifting:** Check for and replace any frayed or degraded cable inner wire and outer casing and check all relevant parts are in correct adjustment for use in accordance with the specific instruction manual
- **Steering and Headset:** Check for loose headset bearings or tight spots when turning the handlebars in both directions, and service, adjust or replace in accordance with the manufacturers specific instruction manual.
- **Tyres:** Check for excessively worn, or cut tyres. Check the inflation pressure is within the recommended range. Refer to the specific manufacturers recommendations.
- **Helmet:** We recommend that for off-Road riding, a helmet meeting a reputable international standard is used and be worn on every ride. Check the helmet is not damaged in any way before riding. Do not ride if your helmet has sustained damage.
- **Riding:** Please be aware, that riding in wet conditions means stopping distances may need to be increased.
- **Replacement Parts:** Where ever possible, please use only genuine replacement parts as instructed by the relevant manufacturers instruction manual.

**Designed and tested for the following use:**

The Whyte E-120 has been designed for typical XC use. It has not been designed for extreme downhill riding or free riding. The E-120 is in compliance with BS-EN 14766:2005

**3.4: WHYTE BIG GRIPPER DROPOUT SYSTEM**

**TO REMOVE WHEEL: Fig. 4a**

Rotate QR lever anti-clockwise to down position.  
Open dropout base.  
Remove wheel by lowering vertically down.

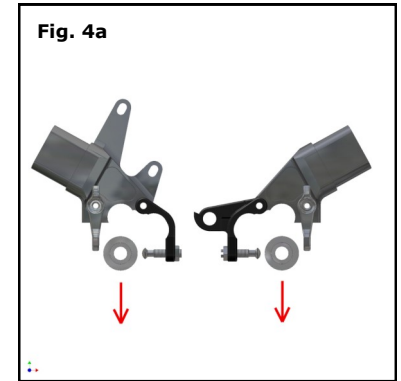

**TO REFIT WHEEL: Fig. 4b**

Place Axle Adapters on wheel into dropout.  
Close Dropout Base.  
Rotate QR lever clockwise to up position.  
Check wheel is secure by pushing down on top of wheel.

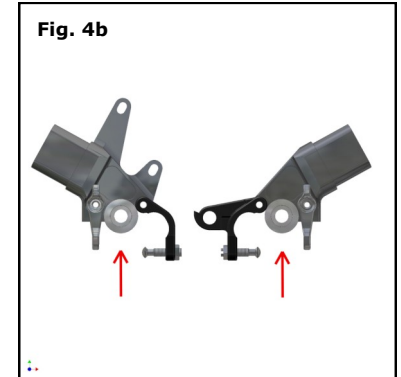

**OK TO RIDE: Fig. 4c**

QR Lever is in up position.  
Dropout Base is closed.

To check if secure, lift bike and push down on top of the wheel.

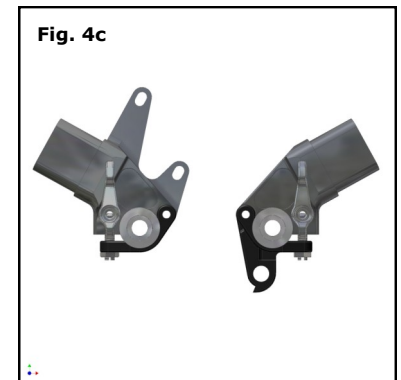

**3.4: WHYTE BIG GRIPPER DROPOUT SYSTEM CONTINUED...**

**DO NOT RIDE: Fig. 4d**

Dropout Base **NOT** closed. QR Lever **Open**

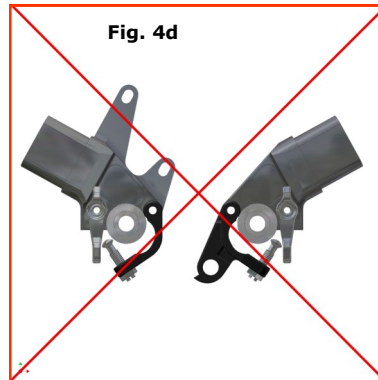

**DO NOT RIDE: Fig. 4e**

QR Lever **NOT** in up position and Closed

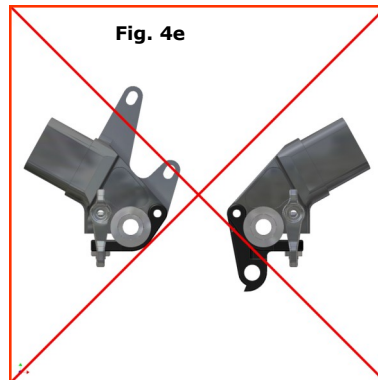

**IMPORTANT SAFETY NOTE:**

If at any stage you are uncertain about the safety or safe operation of the Whyte Big Gripper Dropout System as a whole, or any specific component, please consult your Whyte Dealer for advice.

**4.0: SAFETY**

**IMPORTANT:** The following are intended to be advisory notes on the safe use of your Whyte E-120. If at any stage you are uncertain about the safety or safe operation of the bike as a whole, or any specific component, then **DO NOT RIDE YOUR WHYTE E-120** and instead please consult the specific component manufacturers instruction manual or your Whyte Dealer for advice.

**WARNING:** As is the case with all mechanical components, the bicycle is subjected to wear and high stresses. Different materials and components may react to wear and stress fatigue in different ways. If the design life of a component has been exceeded, it may fail suddenly causing possible injury to the rider. Any form of crack, scratches and decolouring in highly stressed areas are showing that the component has exhausted its life time and has to be replaced. If you are in any doubt about one or more components on your Whyte E-120 **DO NOT RIDE YOUR BIKE**. Consult the specific component manufacturers literature, or take your bike to your local Whyte Dealer.

The Whyte E-120 has a combined maximum weight limit of rider and luggage of no more than 18st. / 114kg

**Before your first ride:**

- **Brake levers:** Familiarise yourself with which brake lever operates which brake. As standard the Whyte E-120 is set-up so as the right-hand brake lever operates the front brake, and the left hand brake lever operates the rear brake.
- **Gear Shifters:** Familiarise yourself with the function and operation of the gear shift levers in accordance with the relevant manufacturers instruction manuals.
- **Whyte Lock On Grips:** Make sure the grips are securely fastened to the handlebars and cannot rotate or become loose at any time during riding.
- **Tyre pressures:** They should be set by your dealer before you collect the bike. However, ensure that the tyre pressures are in between the upper and lower limits as shown on the sidewalls of the tyres.
- **Suspension Settings:** Ensure that you have followed the recommended procedures for setting up the Whyte E-120 suspension systems outlined in Sections 3.2 and 3.3 of this manual
- **IMPORTANT:** please note that you must ensure that your Whyte-E-120 complies with your countries National Legal Requirements when the bicycle is used on public roads.
- **Quick Release Devices:** Please refer to the respective manufacturers instructions on how to operate any quick release devices fitted to the E-120.