



[www.whytebikes.co.uk](http://www.whytebikes.co.uk)



[www.whytebikes.co.uk](http://www.whytebikes.co.uk)



**19 Trail Alloy**  
**19 Trail Ti**  
**19 Trail Steel**  
**19 C, CS, Team & Works**  
**801, 805, 809**  
**901, 905**

**Supplementary Service Manual**  
**Edition 1: July 2010**

**NOTES (continued)**

www.whytebikes.co.uk   
DESIGNED IN THE U.K.



**Table of Contents**

1.0 Introduction

2.0 Geometry:

- 2.1: Whyte 19 Trail Alloy, Trail Titanium & Trail Steel
- 2.2: Whyte 19 C, CS, Race & Works
- 2.3: Whyte 801, 805 & 809
- 2.4: Whyte 901 & 905

3.0 Preparations for riding:

- 3.1 Making Adjustments
- 3.2 Getta-Grip Seat Clamp
- 3.3 Set up of Fork
- 3.4 Whyte 19 Trail Adjustable Dropout System
- 3.5 Adjusting the Whyte 19 Trail Adjustable Dropout System

4.0 Safety.

5.0 Lubrication:

- 5.1 Getta-Grip Seat Clamp
  - 5.1.1: Bolt Up
  - 5.1.2: QR Style
- 5.2 Whyte 19 Trail Alloy, Trail Titanium & Trail Steel Dropout System
- 5.3 General Whyte Hardtail Lubrication

6.0 Torque Settings:

7.0 Notes.

**NOTES (continued)**

**1.0: INTRODUCTION**

Thanks for choosing Whyte. We hope you will enjoy all the benefits its advanced design and engineering will bring to your riding experience.

This manual will guide you through the set-up, safety and maintenance procedures that are specific to your Whyte bike. For other more general information, we strongly advise that you also read thoroughly the General Instruction Manual that is also supplied with your new bike.

Also, please note that the specification of all the components that are fitted to your bike as standard may be obtained from the Whyte Bikes Brochure or alternatively from the Whyte Bikes website **[www.whytebikes.co.uk](http://www.whytebikes.co.uk)**

Please remember, if you are in any doubt about your ability to correctly and safely service or repair your Whyte bike, do not ride it and instead get your local Whyte dealer to do the job safely and correctly.

Bundled with this manual, are the respective manufacturers instructions and manuals for the branded parts that are fitted to your Whyte bike. Please take time to study all the relevant instruction manuals to ensure you have a continually safe and well set-up bike before every ride, and to help you build up a relationship of knowledge between you and your Whyte Dealer.

Happy and safe riding,

*Whyte design team. July 2010.*

**6.0: TORQUE SETTINGS**

Whyte 19 Dropout System	Nm	lbs.ft
M6 x 14mm Pivot Screw	13 - 15	9.5 - 11
M6 x 16mm Clamping Screws	13 - 15	9.5 - 11

*Torque explained: If no suitable Torque Wrench is available a Torque of 5 lbf.ft can be obtained by applying a force of 5lb, with a Spring Balance, to the end of a spanner, 1 Foot in length.*

**IMPORTANT:** For all other torque settings, refer to the specific manufacturers information bundled with this manual, or alternatively, refer to the specific manufacturers website for further information.

**7.0: NOTES**

**2.0: GEOMETRY**

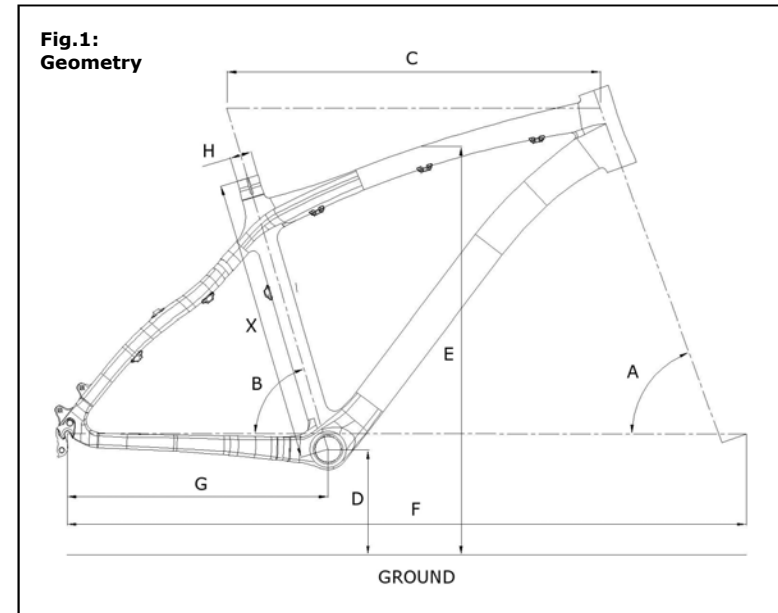

**2.1: WHYTE 19 TRAIL, TI & STEEL**

Frame Size	X	Small	Medium	Large
Head Angle	A	67.7 - 68.2°	67.7 - 68.2°	67.7 - 68.2°
Seat Angle	B	72.2 - 72.7°	72.2 - 72.7°	72.2 - 72.7°
Top Tube	C	565.1mm	584.5mm	609.6mm
BB Height*	D	319.7mm - 325.7mm	319.7mm - 325.7mm	319.7mm - 325.7mm
Stand Over	E	775mm	797mm	823mm
Wheel Base	F	1065.3mm - 1082.5mm	1085.2mm - 1102.4mm	1111.1mm - 1128.3mm
Chain Stay	G	415mm - 435mm	415mm - 435mm	415mm - 435mm
Seat Post	H	30.9mm	30.9mm	30.9mm

Note:  
 Geometry shown here is 'Showroom' i.e. without rider aboard the bicycle. 'With Sag' geometry is with rider after correct sag is set at the front. Please refer to suspension set up for information on how to achieve the correct sag of the fork.  
 \* BB height with Ø67mm tyres fitted (2.25" / 54-559)

**2.2.2: WHYTE 19 C, CS, RACE & WORKS**

Frame Size	X	Small	Medium	Large
Head Angle	A	70.0°	70.0°	70.0°
Seat Angle	B	73.5°	73.5°	73.5°
Top Tube	C	576.2mm	600.9mm	614.0mm
BB Height*	D	311.5mm	311.5mm	311.5mm
Stand Over	E	775mm	794mm	818mm
Wheel Base	F	1077.5mm	1093.0mm	1107.9mm
Chain Stay	G	420mm	420mm	420mm
Seat Post	H	30.9mm	30.9mm	30.9mm

Note:  
Geometry shown here is 'Showroom' i.e. without rider aboard the bicycle. 'With Sag' geometry is with rider after correct sag is set at the front. Please refer to suspension set up for information on how to achieve the correct sag of the fork.  
\* BB height with Ø673mm tyres fitted (2.1" / 52-559)

**2.2.3: WHYTE 801, 805 & 809**

Frame Size	X	Extra Small	Small	Medium	Large	Extra Large
Head Angle	A	68.5°	68.5°	68.5°	68.5°	68.5°
Seat Angle	B	74.0°	73.5°	73.5°	73.0°	73.0°
Top Tube	C	561.5mm	583.8mm	598.5m	617.8mm	628.8mm
BB Height*	D	313.5mm	313.5mm	313.5mm	313.5mm	313.5mm
Stand Over	E	768mm	773mm	797mm	824mm	844mm
Wheel Base	F	1073.9mm	1091.9mm	1107.4mm	1122.2mm	1133.9mm
Chain Stay	G	425mm	425mm	425mm	425mm	425mm
Seat Post	H	30.9mm	30.9mm	30.9mm	30.9mm	30.9mm

Note:  
Geometry shown here is 'Showroom' i.e. without rider aboard the bicycle. 'With Sag' geometry is with rider after correct sag is set at the front. Please refer to suspension set up for information on how to achieve the correct sag of the fork.  
\* BB height with Ø677mm tyres fitted (2.25" / 54-559)

**5.2: WHYTE 19 TRAIL ADJUSTABLE DROPOUT SYSTEM**

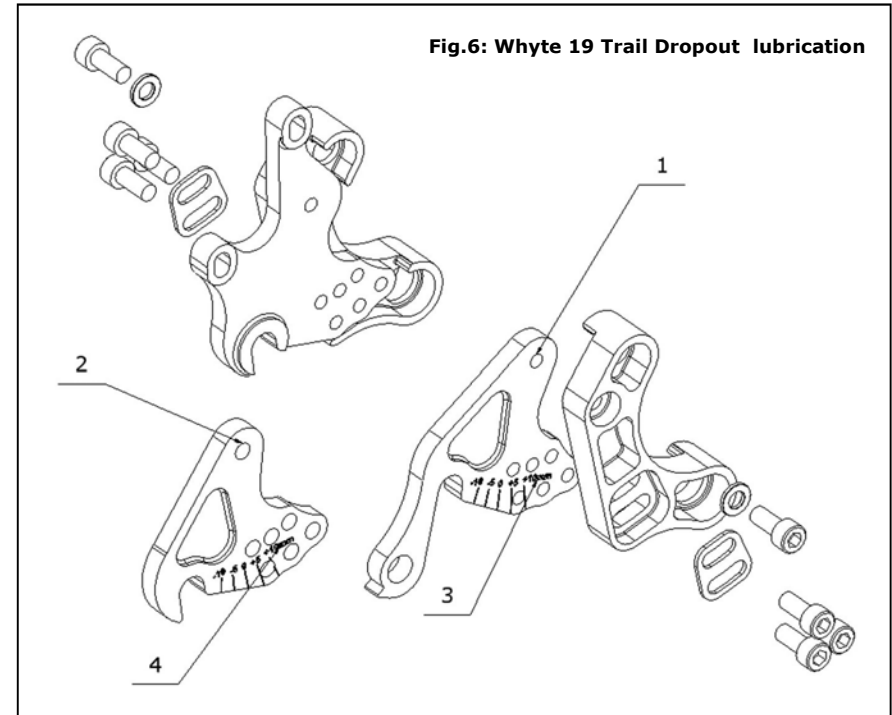

Point	Description	Lubricant	Lubrication Interval
1	LH & RH Dropout Plate Pivot Area (Face Only)	SKF Anti Fret Paste	Check Once a Month
2	RH SS Plate Pivot Area (Face Only)	SKF Anti Fret Paste	Check Once a Month
3	LH & RH Dropout Plate Clamp Area (Face Only)	SKF Anti Fret Paste	Check Once a Month
4	RH SS Plate Clamp Area (Face Only)	SKF Anti Fret Paste	Check Once a Month

**5.3: GENERAL WHYTE HARDTAIL MTB LUBRICATION**

For the correct lubrication regime and maintenance of all parts on a Whyte hardtail bicycle, please refer to the specific component manufacturers detailed instructions bundled with this manual or for further information visit the specific manufacturers website.

**5.0: LUBRICATION**

**5.1: GETTA-GRIP SEAT CLAMP**

**5.1.1: BOLT-UP. Fig.5a**

Point	Description	Lubricant	Lubrication Interval
1	M6 x 30mm Fastener	Castrol LM or equivalent	Once a Month



**5.1.2: QR STYLE. Fig 5.b**

Point	Description	Lubricant	Lubrication Interval
1	Whyte QR Lever Cam Surface	Castrol LM or equivalent	After Every Ride
2	M6 QR Shaft	Castrol LM or equivalent	Once a Month

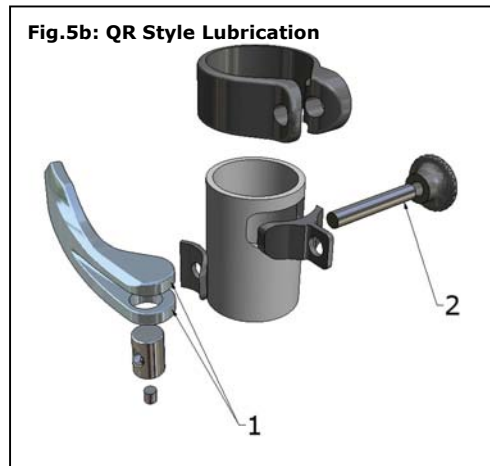

**2.2.4: WHYTE 901 & 905**

Frame Size	X	Small	Medium	Large
Head Angle	A	67.5°	67.5°	67.5°
Seat Angle	B	72.5°	72.5°	72.5°
Top Tube	C	565.1mm	584.5mm	609.6mm
BB Height*	D	322.7mm	322.7mm	322.7mm
Stand Over	E	774mm	800mm	826mm
Wheel Base	F	1080.7mm	1100.9mm	1127.6mm
Chain Stay	G	425mm	425mm	425mm
Seat Post	H	30.9mm	30.9mm	30.9mm

Note:  
 Geometry shown here is 'Showroom' i.e. without rider aboard the bicycle. 'With Sag' geometry is with rider after correct sag is set at the front. Please refer to suspension set up for information on how to achieve the correct sag of the fork.  
 \* BB height with Ø677mm tyres fitted (2.25" / 54-559)

**3.0: PREPARATIONS FOR RIDING**

**3.1: MAKING ADJUSTMENTS**

Please refer to the specific component manufacturer's manual or published technical information about adjusting the components on your Whyte bike. Instructions may be downloaded from the relevant manufacturer's internet site, as shown in the table to the right.

If you are uncertain in any way, about making adjustments to any components on your Whyte bike, then **DO NOT RIDE YOUR BIKE**. Contact your Whyte dealer who will be able to advise you on how to go about setting up your Whyte for riding, and or making adjustments to the components fitted to your Whyte.

Alex Rims	<a href="http://www.alexrim.com">www.alexrim.com</a>
Continental	<a href="http://www.conti-online.com">www.conti-online.com</a>
CST	<a href="http://www.csttires.com">www.csttires.com</a>
DT	<a href="http://www.dtswiss.com">www.dtswiss.com</a>
Easton	<a href="http://www.eastonbike.com">www.eastonbike.com</a>
Fi:zik	<a href="http://www.fizik.it">www.fizik.it</a>
FSA	<a href="http://www.fullspeedahead.com">www.fullspeedahead.com</a>
Fulcrum	<a href="http://www.fulcrumwheels.com">www.fulcrumwheels.com</a>
Formula	<a href="http://www.formulahubs.com">www.formulahubs.com</a>
Fox	<a href="http://www.foxracingshox.com">www.foxracingshox.com</a>
Hayes	<a href="http://www.hayesdiscbrake.com">www.hayesdiscbrake.com</a>
Hope	<a href="http://www.hopetech.com">www.hopetech.com</a>
Mavic	<a href="http://www.mavic.com">www.mavic.com</a>
Maxxis	<a href="http://www.maxxis.com">www.maxxis.com</a>
Shimano	<a href="http://www.shimano.com">www.shimano.com</a>
SRAM	<a href="http://www.sram.com">www.sram.com</a>
Sun Ringle	<a href="http://www.sun-ringle.com">www.sun-ringle.com</a>
Tektro	<a href="http://www.tekro.com">www.tekro.com</a>
TH	<a href="http://www.thindustries.com.tw">www.thindustries.com.tw</a>
Thomson	<a href="http://www.lhthomson.com">www.lhthomson.com</a>
VP	<a href="http://www.vpcomponents.com">www.vpcomponents.com</a>
WTB	<a href="http://www.wtb.com">www.wtb.com</a>

**3.2: WHYTE GETTA-GRIP SEAT CLAMP**

The Getta Grip seat clamp design is a patented design to allow adjustment of the saddle height by either the use of a QR Lever, or bolt-up method. This manual covers both styles of clamps.

**ADJUSTING THE WHYTE 19 TRAIL DROPOUT SYSTEM (Continued).**

To adjust the Dropout Plates (3,6,7), first secure the bike into a work stand. Next, using the 5mm Allen Key, loosen off the RH and LH top M6x14mm Socket head Cap Screws (5a) by one turn only. Next Remove the three RH and three LH lower M6 x 14 Screws (5b) from the bike, taking care to collect both Dropout M6 Washer Plates (8). You will now be able to rotate both the RH and LH Dropout Plates (3,6,7) around the top pivot screw (5a) to adjust the chain stay lengths. Align the chosen Laser Etch marks on the Dropout Plates (3,6,7) with the edge of the mainframe dropouts (1,2) and re-assemble the Dropout M6 Washer Plates (8) and the three M6 x 14mm Socket Head Screws (5b). Before finally tightening all M6 Fasteners, double check the LH and RH dropout plate (3,6,7) Laser Etch marks correspond correctly to each other, and that the rear wheel is aligned properly in the frame. Finally tighten Screws (5a and 5b) to the torque setting described in Section 6.0

**4.0: SAFETY**

**IMPORTANT:** The following are intended to be advisory notes on the safe use of your Whyte bike. You should also read thoroughly the General Instruction Manual also supplied with your new bike. If at any stage you are uncertain about the safety or safe operation of the bike as a whole, or any specific component, then **DO NOT RIDE YOUR WHYTE** and instead please consult the specific component manufacturer's instruction manual or your Whyte Dealer for advice.

**Maximum Rider Weight Limit for Whyte Hardtail MTB Series':**  
19 Stone/120kg



**WARNING:** As is the case with all mechanical components, the bicycle is subjected to wear and high stresses. Different materials and components may react to wear and stress fatigue in different ways. If the design life of a component has been exceeded, it may fail suddenly causing possible injury to the rider. Any form of crack, scratches and decolouring in highly stressed areas are showing that the component has exhausted its life time and has to be replaced. If you are in any doubt about one or more components on your Whyte **DO NOT RIDE YOUR BIKE**. Consult the specific component manufacturer's literature, or take your bike to your local Whyte Dealer.

**Designed for the following use:**

All bicycles in the Whyte Hardtail MTB series' have all been designed, tested and comply with BS EN 14766 Standard, for typical cross country mountain biking use. They have not been designed or tested for extreme down-hilling or free-riding.

3.5: ADJUSTING THE WHYTE 19 TRAIL DROPOUT SYSTEM



Fig.4a: Max RH Chain Stay



Fig.4b: Max LH Chain Stay



Fig.4c: Min RH Chain Stay



Fig.4d: Min LH Chain Stay

**ADJUSTING THE WHYTE 19 TRAIL DROPOUT SYSTEM: Fig.4 4a,4b,4c,4d**

*Tools Required: 5mm A/F Allen Key*

The Whyte 19 dropout system enables a rider to adjust the bike's Chain stay length. This allows the rider to tune the handling characteristics to their preference, or when used in conjunction with the Single Speed RH Dropout Plate (7), a single speed drive-train can be used without the need for a chain tensioner device because the dropouts (3,6,7) can be adjusted to tension the chain exactly.

Item:	Description
1	Whyte Seat Clamp Band
2	T-Pad
3	Whyte Main Frame
4	Barrel Nut
5	M6 x 30mm Fastener
6	M6 Washer



**Bolt-up Type: Fig.2**

*Tools Required: 5mm Allen Key*

*(Note, refer to the seat-pin manufacturers instructions in conjunction with these notes).*

To adjust the seat height, using the 5mm Allen key, undo the M6 bolt (5) just enough to allow the seat-pin to slide freely up and down. Set the height to the desired level, and re-tighten the M6 bolt (5) with the 5mm Allen Key just enough so as to prevent the seat-pin from slipping down and twisting.

Item	Description
1	QR Lever Cam Grub Screw
2	QR Lever Cam
3	Whyte QR Lever
4	Plastic Shim
5	Whyte Main Frame
6	Whyte Seat Clamp Band
7	QR Adjuster Bobbin
8	QR Shaft
9	T-Pad

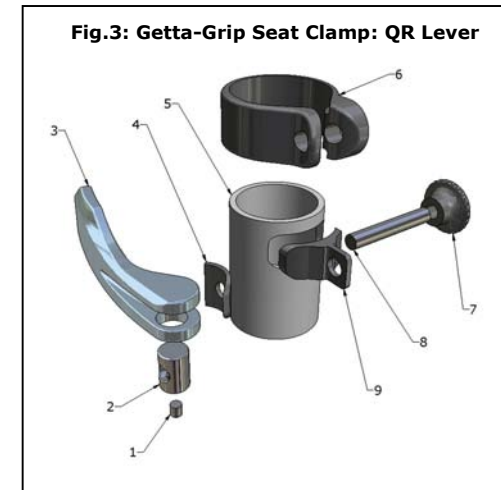

**QR Lever Type: Fig.3**

*No tools required.*

*(Note, refer to the seat-pin manufacturers instructions in conjunction with these notes).*

To Adjust the seat height with the QR Lever assembly fitted, simply undo the QR Lever (3) from the Closed position to the Open position. Next adjust the height of the Seat Pin to the desired level, and close the QR lever (3) from the Open position to the Closed position. The QR closing force can be adjusted by turning the QR Adjuster Bobbin (7) clockwise or anti-clockwise before closing the QR Lever (3).

**3.3: SET UP OF FORK**

*Tools Required: Good Quality Shock Pump.  
Small Ruler*

The front fork will be pre-set with the standard settings when you buy your Whyte. Before riding, you will need to adjust the Sag setting on the fork. This is to ensure the forks are set-up correctly for your own body weight, so the fork will perform as intended.

To set Sag on a front fork, you need to measure the amount the fork compresses when you sit on the bike in the normal riding position. We recommend for the best performance to run approximately (16%) Sag on the front fork.

Sag on and air sprung fork is controlled by adjusting the Air Spring pressure. We recommend you refer to your forks owners manual or releveant website for detailed information about your fork set up and performance relating to all controls and features of your fork.

**Rebound Damping adjustment:**

This adjustment fine-tunes the speed at which the wheel returns to its normal ride height after hitting a bump. To demonstrate the effect of this function, turn the rebound adjuster to its slowest setting. Press down on the handlebars to compress the forks, then release the load. The suspension recovers very slowly to its original position.

Repeat the above with the adjuster turned to the fastest setting and the difference will be seen immediately the load is released. We recommend the optimum setting is to adjust the re-bound damping to be as slow as possible, but not so slow that the normal ride height is not recovered. On very rough terrain, if the bike becomes progressively lower as more bumps are hit then the re-bound damping is set too slow. On the other hand if the bike feels choppy and not plush then the re-bound damping is too fast. A bit of trial and error is needed to get the exact setting. **WARNING.** Only make adjustments to your fork while stationary, and not when riding.

**3.4: WHYTE 19 TRAIL ADJUSTABLE DROPOUT SYSTEM**

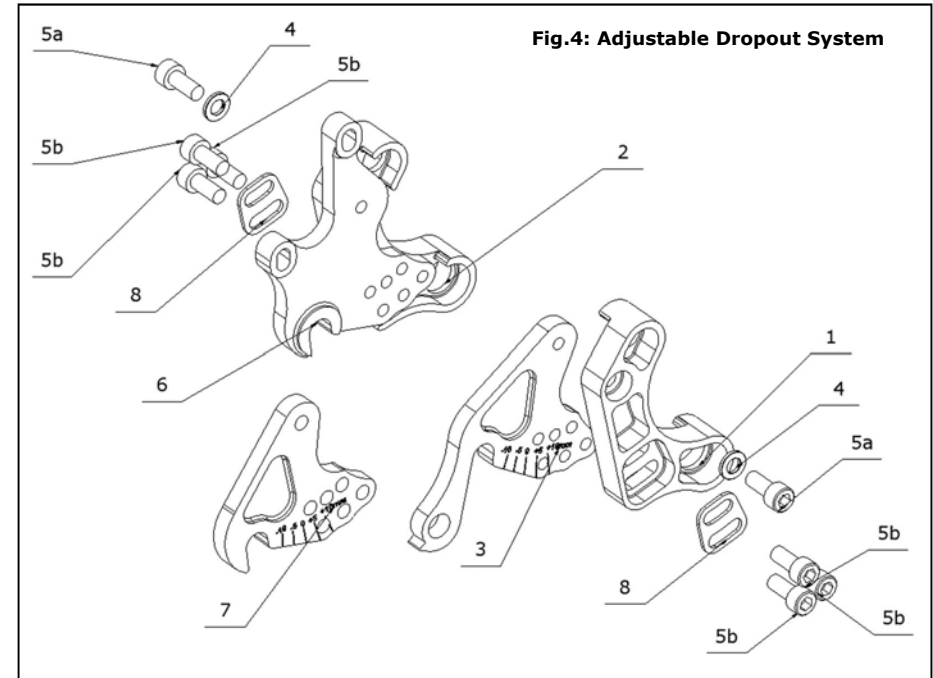

**Fig.4: Adjustable Dropout System**

Point	Description.	Quantity.
1	Whyte 19 RH Dropout (Main Frame)	-
2	Whyte 19 LH Dropout (Main Frame)	-
3	RH Dropout (Mech Hanger Type)	1
4	M6 Washer	2
5a	M6 x 14mm Socket Head Cap Screw (Top, Dropout Pivot)	8
5b	M6 x 14mm Socket Head Cap Screw (Bottom, Dropout Clamping)	
6	LH Dropout/Disc Mount	1
7	RH Dropout (Single Speed Type)	1
8	Dropout M6 Washer Plate	2

**IMPORTANT SAFETY NOTE:**

If at any stage you are uncertain about safety or the safe adjustment of the Whyte 19 Dropout System as a whole, or any specific component, please do not ride your bike, and consult your Whyte Dealer for advice.