



www.whytebikes.com 



www.whytebikes.com 

19 Trail
19 Trail Ti
19 Steel 631
19 C, Race and Works XX
901
905

2010 Service and Instruction Manual
Edition 1: October 2009

NOTES (continued)

www.whytebikes.com 

Table of Contents

- 1.0 Introduction
- 2.0 Specifications and Geometry:
 - 2.1 Specifications
 - 2.1.1: Whyte 19 Trail
 - 2.1.2: Whyte 19 Trail Ti
 - 2.1.3: Whyte 19 Steel 631
 - 2.1.4: Whyte 19 C
 - 2.1.5: Whyte 19 Race
 - 2.1.6: Whyte 19 Works XX
 - 2.1.7: Whyte 901
 - 2.1.8: Whyte 905
 - 2.2 Geometry
 - 2.2.1: Whyte 19 Trail, Trail Titanium & Steel 631
 - 2.2.2: Whyte 901 & 905
 - 2.2.3: Whyte 19 C, Race & Works XX
- 3.0 Preparations for riding:
 - 3.1 Making Adjustments
 - 3.1.1: Getta-Grip Seat Clamp
 - 3.1.2: Cockpit adjustments
 - 3.2 Set up of Fork
 - 3.3 Whyte 19 Trail, Trail Titanium & Steel 631 Dropout System
 - 3.4 Adjusting the Whyte 19 Trail, Trail Titanium & Steel 631 Dropout System
- 4.0 Safety.
- 5.0 Lubrication:
 - 5.1 Getta-Grip Seat Clamp
 - 5.1.1: Bolt Up
 - 5.1.2: QR Style
 - 5.2 Whyte 19 Trail, Trail Titanium & Steel 631 Dropout System
 - 5.3 General Whyte 19, 901 and 905 Lubrication
- 6.0 Torque Settings:
- 7.0 Notes.

1.0: INTRODUCTION

Thanks for choosing Whyte. We hope you will enjoy all the benefits the advanced design and engineering will bring to your riding experience.

This manual will guide you through the necessary set-up, safety and maintenance procedures involved in using and servicing your frameset.

Bundled with this manual, are the respective manufacturers instructions and manuals for the branded parts that go to make up the Whyte build. Please take time to study both this manual and all the relevant instruction manuals to ensure you have a continually safe and well set-up bike before every ride, and to help you build up a relationship of knowledge between you and your Whyte Dealer.

Happy and Safe riding.

Whyte design team. October 2009.

6.0: TORQUE SETTINGS

Whyte 19 Dropout System	Nm	lbs.ft
M6 x 14mm Pivot Screw	13 - 15	9.5 - 11
M6 x 16mm Clamping Screws	13 - 15	9.5 - 11

Torque explained: If no suitable Torque Wrench is available a Torque of 5 lbf.ft can be obtained by applying a force of 5lb, with a Spring Balance, to the end of a spanner, 1 Foot in length.

IMPORTANT: For all other torque settings, refer to the specific manufacturers information bundled with this manual, or alternatively, refer to the specific manufacturers website for further information.

7.0: NOTES

2.0: WHYTE SPECIFICATIONS AND GEOMETRY

2.1: SPECIFICATIONS

2.1.1: WHYTE 19 TRAIL

Frame	6061 Hyrdro Formed T6 Aluminium, Custom Drawn, Multi Butted with Adjustable Modular Dropouts
Fork	Fox F120 RL QR15
Shifters	SRAM X-9
Brake Levers	Hope, Tech lever
Crankset	Truvative Stylo 3.3 22/32/44 with Gold chainring bolts
Chain	SRAM PC-971
Front Mech	SRAM X-9
Rear Mech	SRAM X-0 Long Cage
Cassette	SRAM PG-990 11-34
Rear Hub	Hope II Pro Disc Hub 32 Hole with Shimano XT QR
Front Hub	Hope II Pro QR15 Disc Hub 32 Hole with Shimano XT QR
BB	SRAM GPX
Brakes	Hope X2, With Tech Carbon Lever, 180mm front rotor and 160mm Rear Rotor
Rims	Mavic XM-719, 32 Hole, Black
Spokes	DT Competition Butted 1.8-1.6-1.8mm, Black Stainless with Brass Nipples
Tyres	Maxxis Aspen 26 x 2.25 DKFW AR 635g
Headset	FSA Orbit Z, Sealed Cartridge Bearings
Seatpost	Thomson In-line, 30.9mm x 410mm
Saddle	Fi'zi:k Gobi XM with Mag Rails
Bar	Easton MonkeyBar XC Low Rise, 31.8mm OD 685mm wide
Stem	Thomson 31.8mm 70mm S, 90mm M, 100mm L
Grips	Whyte Semi Lock-on's

2.1.2: WHYTE 19 Trail Ti

Frame	3AL2.5V Aerospace Grade Titanium Alloy, Custom Cold-drawn
Fork	Fox F120 RL QR15, 120mm Travel
Shifters	SRAM X-9
Brake Levers	Hope Tech Levers
Crankset	FSA Afterburner Crankset BB30, 44/32/22
Chain	SRAM PC-971
Front Mech	SRAM X-9
Rear Mech	SRAM X-0 Long Cage
Cassette	SRAM PG-990 11-34
Rear Hub	Hope II Pro Disc Hub 32 Hole with Shimano XT QR
Front Hub	Hope II Pro Disc Hub 15mm 32 Hole
BB	BB30
Brakes	Hope X2 With Hope Tech Levers, 180mm front rotor with 160mm rear rotor
Rims	Mavic XM-719, 32 Hole, Black
Spokes	DT Competition Butted 1.8-1.6-1.8mm, Black Stainless with Brass Nipples
Tyres	Panaracer Cinder 26 X 2.25" with Kevlar Bead
Headset	FSA Orbit MX, Sealed Cartridge Bearings
Seatpost	Thomson In-line, 30.9mm x 410mm
Saddle	Fi'zi:k Gobi with Mag Rails
Bar	Easton Monkeylite XC Low Rise, 31.8mm OD
Stem	Thomson Elite X-4, 31.8mm Bar Clamp, 90mm S & M, 100mm L
Grips	Whyte Semi Lock-on's

5.2: WHYTE 19 DROPOUT SYSTEM

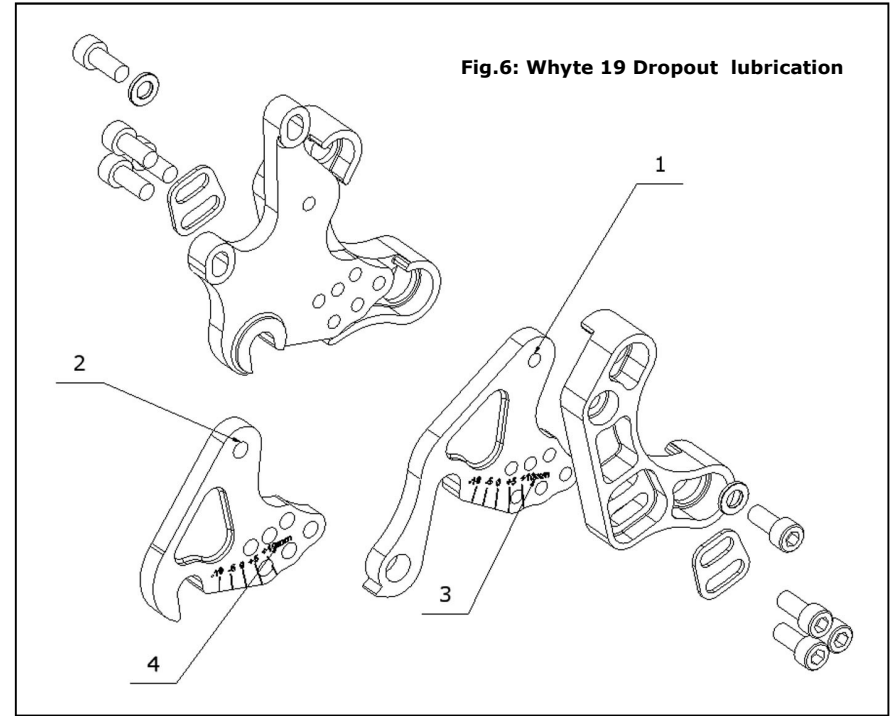

Point	Description	Lubricant	Lubrication Interval
1	LH & RH Dropout Plate Pivot Area (Face Only)	SKF Anti Fret Paste	Check Once a Month
2	RH SS Plate Pivot Area (Face Only)	SKF Anti Fret Paste	Check Once a Month
3	LH & RH Dropout Plate Clamp Area (Face Only)	SKF Anti Fret Paste	Check Once a Month
4	RH SS Plate Clamp Area (Face Only)	SKF Anti Fret Paste	Check Once a Month

5.3: GENERAL WHYTE LUBRICATION

For the correct lubrication regime and maintenance of all parts on a Whyte hardtail bicycle, please refer to the specific component manufacturers detailed instructions bundled with this manual or for further information visit the specific manufacturers website.

5.0: LUBRICATION

5.1: GETTA-GRIP SEAT CLAMP

5.1.1: BOLT-UP. Fig.5a

Point	Description	Lubricant	Lubrication Interval
1	M6 x 30mm Fastener	Castrol LM or equivalent	Once a Month

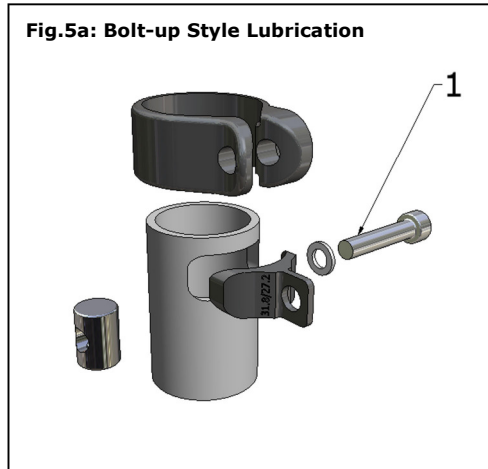

5.1.2: QR STYLE. Fig 5.b

Point	Description	Lubricant	Lubrication Interval
1	Whyte QR Lever Cam Surface	Castrol LM or equivalent	After Every Ride
2	M6 QR Shaft	Castrol LM or equivalent	Once a Month

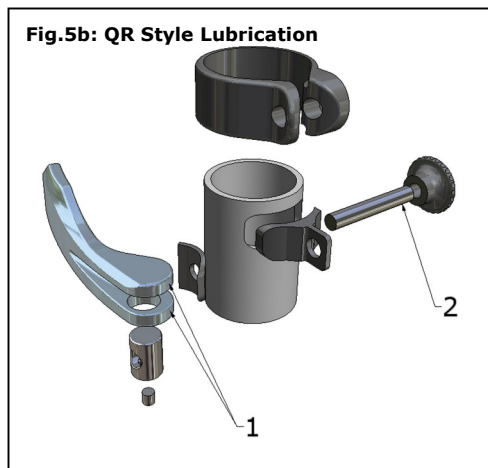

2.1.3: WHYTE 19 Steel 631

Frame	Reynolds 631 Manganese & Molybdenum Alloy Steel, Seamless Custom Butted, Air-Hardened
Fork	RockShox Reba SL, Maxle Light 120mm Travel, Motion Control Damping with TurnKey Lock-out
Shifters	SRAM X-9
Brake Levers	Avid Elixir R
Crankset	FSA Afterburner Crankset BB30, 44/32/22
Chain	SRAM PC-971
Front Mech	SRAM X-5
Rear Mech	SRAM X-9 Long Cage
Cassette	SRAM PG-950 11-34
Rear Hub	Hope II Pro Disc Hub 32 Hole with Shimano XT QR
Front Hub	Double Sealed Bearing Hub 20mm, 32 Hole
BB	BB30
Brakes	Avid Elixir R, White, 180mm Front and 160mm Rear Rotors
Rims	Mavic XM-719, 32 Hole, Black
Spokes	DT Competition Butted 1.8-1.6-1.8mm, Black Stainless with Brass Nipples
Tyres	Maxxis Aspen 26 x 2.25 DK60 AR Folding Bead
Headset	FSA Orbit MX, Sealed Cartridge Bearings
Seatpost	Truvative Stylo Race, 30.9mm x 400mm
Saddle	Fi'zi:k Gobi with Mag Rails
Bar	Truvative Stylo Race, 31.8mm OD, 25.4mm Rise, 680mm long
Stem	Truvative Stylo Race, 60mm S, 75mm M, 90mm L
Grips	Whyte Semi Lock-on's

2.1.4: WHYTE 19 C

Frame	Uni-directional Multi Monocoque
Fork	RockShox SID Race 100mm Travel, Remote Push-lock Motion Control
Shifters	Shimano XT SL-M660
Brake Levers	Stroker Carbon
Crankset	FSA Afterburner Crankset BB30, 44/32/22
Chain	Shimano HG-73
Front Mech	Shimano XT FD-M660
Rear Mech	Shimano XT RD-M772, Shadow
Cassette	Shimano CS-M660 11-34
Rear Hub	Fulcrum Red Metal 5 wheel set with 6 bolt hub
Front Hub	Fulcrum Red Metal 5 wheel set with 6 bolt hub
BB	BB30
Brakes	Hayes Stroker Carbons, 160mm Rotors
Rims	Fulcrum Metal 5
Spokes	Fulcrum StSt Bladed
Tyres	Continental Race King 26 X 2.1" with Kevlar Bead
Headset	FSA Integrated Headset, Orbit ZS-CF Sealed Cartridge Bearings
Seatpost	FSA, Carbon SL-280 30.9mm x 350mm
Saddle	Fi'zi:k Tundra XM with Mag Rails
Bar	FSA, Carbon, K-Force, 19mm Rise, 630mm Wide
Stem	FSA, 150 XTR, with Carbon Face Plate, 80mm S, 90mm M, 100mm L
Grips	Whyte Semi Lock-on's

IMPORTANT: please note that you must ensure that your Whyte complies with your countries National Legal Requirements when the bicycle is used on public roads.

After Every Ride:

- **Post-Ride cleaning:** We strongly recommend cleaning your bike after every ride. This provides you with the best opportunity of a close and systematic inspection of almost every component, for damage and wear on a ride by ride basis.
- **Lubrication:** Directly after cleaning your bike after a ride, is the best time to carry out the lubrication regime for the various components as outlined in this manual, and in the respective component manufactures technical information.

Before every ride: Pre-ride safety check.

- **Frameset Components:** We recommend that before every ride you visually inspect the mainframe and associated components for signs of damage or excessive wear due to hard use.
- **Brakes:** Check the Disc and Brake pads for wear and performance degradation, and the hydraulic hoses for damage, in accordance with the specific recommendations in the relevant component makers instruction manual bundled with this manual.
- **Wheels:** Check both wheels are securely attached to the bike, and the respective dropout systems are correctly adjusted. Check the condition of both wheels, and look for cracks or large dents in the aluminium rims, and check for loose or broken spokes and/or spoke nipples, and wheels out of alignment in line with the specific recommendations in the relevant instruction manual bundled with this manual.
- **Lubrication:** Check all parts have been lubricated in accordance with the specific component makers instruction manual.
- **Gear Shifting:** Check for and replace any frayed or degraded cable inner wire and outer casing and check all relevant parts are in correct adjustment for use in accordance with the specific instruction manual
- **Steering and Headset:** Check for loose headset bearings or tight spots when turning the handlebars in both directions, and service, adjust or replace in accordance with the manufacturers specific instruction manual.
- **Tyres:** Check for excessively worn, or cut tyres. Check the inflation pressure is within the recommended range. Refer to the specific manufacturers recommendations.
- **Helmet:** We recommend that for off-Road riding, a helmet meeting a reputable international standard is used and be worn on every ride. Check the helmet is not damaged in any way before riding. Do not ride if your helmet has sustained damage.

Designed for the following use:

The Whyte 19 Trail, 19 Trail Ti, 19 Steel 631, 19 C, 19 Race, 19 Works XX, 901 and 905 have all been designed, tested and comply with BS EN 14766 Standard, for typical Cross Country Mountain Biking use. They have not been designed or tested for extreme downhill or Free-Riding.

ADJUSTING THE WHYTE 19 DROPOUT SYSTEM. Continued.

To adjust the Dropout Plates (3,6,7), first secure the bike into a work stand. Next, using the 5mm Allen Key, loosen off the RH and LH top M6x14mm Socket head Cap Screws (5a) by one turn only. Next Remove the three RH and three LH lower M6 x 14 Screws (5b) from the bike, taking care to collect both Dropout M6 Washer Plates (8). You will now be able to rotate both the RH and LH Dropout Plates (3,6,7) around the top pivot screw (5a) to adjust the chain stay lengths. Align the chosen Laser Etch marks on the Dropout Plates (3,6,7) with the edge of the mainframe dropouts (1,2) and re-assemble the Dropout M6 Washer Plates (8) and the three M6 x 14mm Socket Head Screws (5b). Before finally tightening all M6 Fasteners, double check the LH and RH dropout plate (3,6,7) Laser Etch marks correspond correctly to each other, and that the rear wheel is aligned properly in the frame. Finally tighten Screws (5a and 5b) to the torque setting described in Section 6.0

4.0: SAFETY

IMPORTANT: The following are intended to be advisory notes on the safe use of your Whyte. If at any stage you are uncertain about the safety or safe operation of the bike as a whole, or any specific component, then **DO NOT RIDE YOUR WHYTE** and instead please consult the specific component manufacturers instruction manual or your Whyte Dealer for advice.

Maximum Rider Weight Limit for Whyte 19 Trail, 19 Team, 19 Race, 901 and 905:
19 Stone/120kg

WARNING: As is the case with all mechanical components, the bicycle is subjected to wear and high stresses. Different materials and components may react to wear and stress fatigue in different ways. If the design life of a component has been exceeded, it may fail suddenly causing possible injury to the rider. Any form of crack, scratches and decolouring in highly stresses areas are showing that the component has exhausted its life time and has to be replaced. If you are in any doubt about one or more components on your Whyte **DO NOT RIDE YOUR BIKE**. Consult the specific component manufacturers literature, or take your bike to your local Whyte Dealer.

Before your first ride:

- **Brake levers:** Familiarise yourself with which brake lever operates which brake. As standard the Whyte is set-up so as the right-hand brake lever operates the front brake, and the left hand brake lever operates the rear brake.
- **Gear Shifters:** Familiarise yourself with the function and operation of the gear shift levers in accordance with
- **Whyte Lock On Grips:** Make sure the grips are securely fastened to the handlebars and cannot rotate or become loose at any time during riding.
- **Tyre pressures:** They should be set by your dealer before you collect the bike. However, ensure that the tyre pressures are in between the upper and lower limits as shown on the sidewalls of the tyres.
- **Suspension Settings:** Ensure that you have followed the recommended procedures for setting up the Whyte suspension systems outlined in Sections 3.2

2.1.5: WHYTE 19 RACE

Frame	Uni-directional Multi Monocoque
Fork	RockShox SID Race 100mm Travel, Remote Push-lock Motion Control
Shifters	Shimano XT SL-M770
Brake Levers	Shimano XT
Crankset	FSA Afterburner Crankset BB30, 44/32/22
Chain	Shimano HG-73
Front Mech	Shimano XT FD-M770
Rear Mech	Shimano XT RD-M772, Shadow
Cassette	Shimano CS-M770 11-34
Rear Hub	Fulcrum Red Metal 3 wheel set with Centre Lock wheels
Front Hub	Fulcrum Red Metal 3 wheel set with Centre Lock wheels
BB	BB30
Brakes	Shimano XT
Rims	Fulcrum Metal 3, tubless compatible
Spokes	Fulcrum StSt Bladed
Tyres	Maxxis Aspen, 26" X 2.1" DKFW AR Folding
Headset	FSA Integrated Headset, Orbit ZS-CF Sealed Cartridge Bearings
Seatpost	FSA, Carbon SL-K 30.9mm x 350mm
Saddle	Fi'zi:k Tundra XM with Mag Rails
Bar	FSA, Carbon, K-Force, 19mm Rise, 630mm Wide
Stem	FSA, 150 XTR, with Carbon Face Plate, 80mm S, 90mm M, 100mm L
Grips	Whyte Semi Lock-on's

2.1.6: WHYTE 19 Works XX

Frame	Uni-directional Multi Monocoque
Fork	RockShox SID XX 100mm Travel, Remote Push-Lock Motion Control
Shifters	SRAM XX
Brake Levers	SRAM XX
Crankset	SRAM XX, 45/30 Double Chainset, BB30 Oversize Axle
Chain	SRAM XX
Front Mech	SRAM XX
Rear Mech	SRAM XX
Cassette	SRAM XX 11-36 10 speed
Rear Hub	Fulcrum Red Metal 1 Tubless Wheelset
Front Hub	Fulcrum Red Metal 1 Tubless Wheelset
BB	BB30
Brakes	SRAM XX
Rims	Fulcrum Tubeless
Spokes	Fulcrum
Tyres	Maxxis Aspen 26 x 2.1 DKFW AR 465g
Headset	FSA Integrated Headset, Orbit ZS-CF, Sealed Cartridge Bearings
Seatpost	Easton EC90 30.9mm x 400mm
Saddle	Fi'zi:k Tundra with Ti Rails
Bar	Easton Monkeylite SL Low Rise, 31.8mm OD, 635mm Wide
Stem	Easton EA70, 31.8mm Bar Clamp, 90mm S, 100mm M, 110mm L
Grips	Whyte Semi Lock-on's

3.4: ADJUSTING THE WHYTE 19 DROPOUT SYSTEM

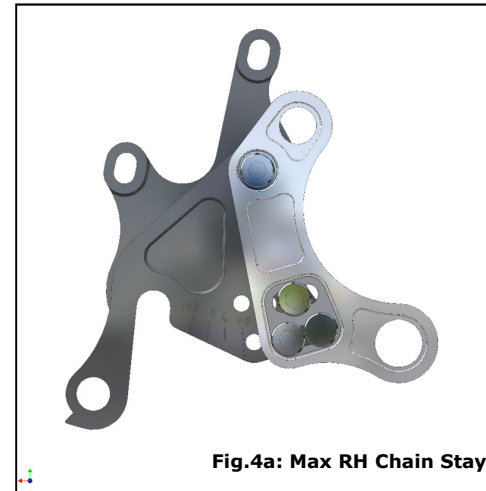

Fig.4a: Max RH Chain Stay



Fig.4b: Max LH Chain Stay

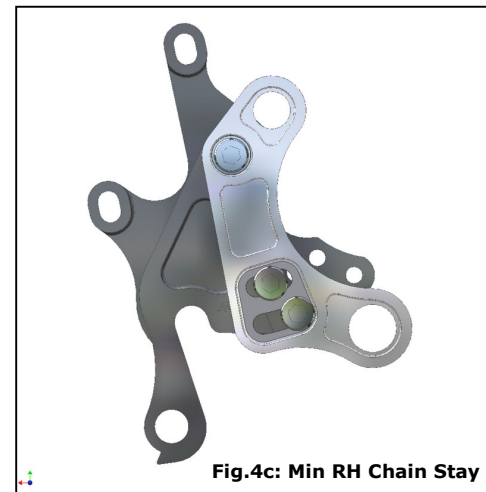

Fig.4c: Min RH Chain Stay



Fig.4d: Min LH Chain Stay

ADJUSTING THE WHYTE 19 DROPOUT SYSTEM: Fig.4 4a,4b,4c,4d

Tools Required: 5mm A/F Allen Key

The Whyte 19 dropout system enables a rider to adjust the bike's Chain stay length. This allows the rider to tune the handling characteristics to their preference, or when used in conjunction with the Single Speed RH Dropout Plate (7), a single speed drive-train can be used without the need for a chain tensioner device because the dropouts (3,6,7) can be adjusted to tension the chain exactly.

3.3: WHYTE 19 DROPOUT SYSTEM

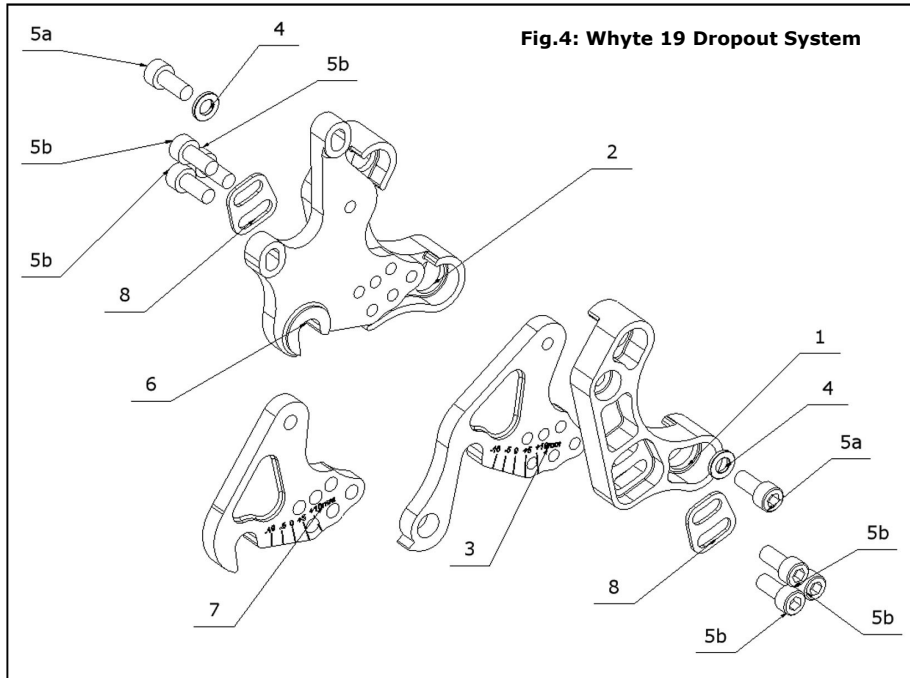

Point	Description.	Quantity.
1	Whyte 19 RH Dropout (Main Frame)	-
2	Whyte 19 LH Dropout (Main Frame)	-
3	RH Dropout (Mech Hanger Type)	1
4	M6 Washer	2
5a	M6 x 14mm Socket Head Cap Screw (Top, Dropout Pivot)	8
5b	M6 x 14mm Socket Head Cap Screw (Bottom, Dropout Clamping)	
6	LH Dropout/Disc Mount	1
7	RH Dropout (Single Speed Type)	1
8	Dropout M6 Washer Plate	2

IMPORTANT SAFETY NOTE:

If at any stage you are uncertain about safety or the safe adjustment of the Whyte 19 Dropout System as a whole, or any specific component, please do not ride your bike, and consult your Whyte Dealer for advice.

2.1.7: WHYTE 901

Frame	6061 Hydro Formed T6 Aluminium, Custom Drawn and Multi Butted
Fork	RockShox Recon Race, Maxle Light 120mm Travel, Solo Air, Adjustable compression
Shifters	SRAM X-5
Brake Levers	SRAM Elixir 5
Crankset	Truvativ Firex 3.1, 44/32/22
Chain	SRAM PC-971
Front Mech	SRAM X-5
Rear Mech	SRAM X-9 Red Anodized
Cassette	Shimano SLX 11-34
Rear Hub	Alloy, Double Sealed Bearing Hub, 32 Hole
Front Hub	Alloy, Double Sealed Bearing Hub 20mm, 32 Hole
BB	SRAM GXP
Brakes	Elixir 5, White, 180mm Front Rotor and 160mm Rear Rotor
Rims	Mavic XM 117, 32 Hole
Spokes	DT Competition Butted 1.8-1.6-1.8mm, Black Stainless with Brass Nipples
Tyres	Continental Mountain King Fold 2.2" X 26" Kevlar
Headset	FSA Orbit Z, Steel Sealed Cartridge Bearings
Seatpost	Truvativ Stylo Race, 30.9mm x 400mm
Saddle	SDG Bel Air RL
Bar	Truvative Stylo Race, 31.8mm OD, 25.4 Rise, 680mm Long
Stem	Truvativ Stylo Race, 31.8mm Bar Clamp, 60mm S, 75mm M, 90mm L
Grips	Whyte Semi Lock-on's

2.1.8: WHYTE 905

Frame	6061 Hydro Formed T6 Aluminium, Custom Drawn and Multi Butted
Fork	RockShox Reba SL, Maxle Light 120mm Travel, Motion Control Damping with TurnKey Lock-out
Shifters	Shimano Deore
Brake Levers	Hayes Stroker Trail
Crankset	Shimano SLX FC-M660, 44/32/22 with Hollowtech II Arms
Chain	SRAM PC-971
Front Mech	Shimano Deore
Rear Mech	Shimano SLX Shadow, RD-M662
Cassette	Shimano SLX 11-34
Rear Hub	Hope II Pro Disc Hub 32 Hole with Shimano XT QR
Front Hub	Double Sealed Bearing Hub 20mm, 32 Hole
BB	Shimano Big Pipe Billet Integrated with Crankset
Brakes	Hayes Stroker Trail, 180mm Front and 160mm Rear Rotors
Rims	Mavic XM 317, 32 Hole
Spokes	DT Competition Butted 1.8-1.6-1.8mm, Black Stainless with Brass Nipples
Tyres	Maxxis Aspen 26 X 2.25", DK60 AR Folding Bead
Headset	FSA Orbit Z, Steel Sealed Cartridge Bearings
Seatpost	Easton EA50, 30.9mm x 350mm
Saddle	Fi'zi:k Gobi XM Mag Rails
Bar	EA70 MonkeyBar XC Mid Rise, 31.8mm OD, 685mm
Stem	Easton EA50, 31.8mm Bar Clamp, 70mm XS & S, 80mm M, 90mm L
Grips	Whyte Semi Lock-on's

3.2: SET UP OF FORK

Tools Required: Good Quality Shock Pump.

The front fork will be pre-set with the standard settings when you buy your Whyte. Before riding, you will need to adjust the Sag setting on the fork. This is to ensure the forks are set-up correctly for your own body weight, so the fork will perform as intended.

To set Sag on a front fork, you need to measure the amount the fork compresses when you sit on the bike in the normal riding position. We recommend for the best performance to run approximately (16%) Sag on the front fork.

Sag on an air sprung fork is controlled by adjusting the Air Spring pressure. We recommend you refer to your forks owners manual or relevant website for detailed information about your fork set up and performance relating to all controls and features of your fork.

Rebound Damping adjustment:

This adjustment fine-tunes the speed at which the wheel returns to its normal ride height after hitting a bump. To demonstrate the effect of this function, turn the rebound adjuster to its slowest setting. Press down on the handlebars to compress the forks, then release the load. The suspension recovers very slowly to its original position.

Repeat the above with the adjuster turned to the fastest setting and the difference will be seen immediately the load is released. We recommend the optimum setting is to adjust the re-bounce damping to be as slow as possible, but not so slow that the normal ride height is not recovered. On very rough terrain, if the bike becomes progressively lower as more bumps are hit then the re-bounce damping is set too slow. On the other hand if the bike feels choppy and not plush then the re-bounce damping is too fast. A bit of trial and error is needed to get the exact setting. **WARNING.** Only make adjustments to your fork while stationary, and not when riding.

Item	Description
1	QR Lever Cam Grub Screw
2	QR Lever Cam
3	Whyte QR Lever
4	Plastic Shim
5	Whyte Main Frame
6	Whyte Seat Clamp Band
7	QR Adjuster Bobbin
8	QR Shaft
9	T-Pad

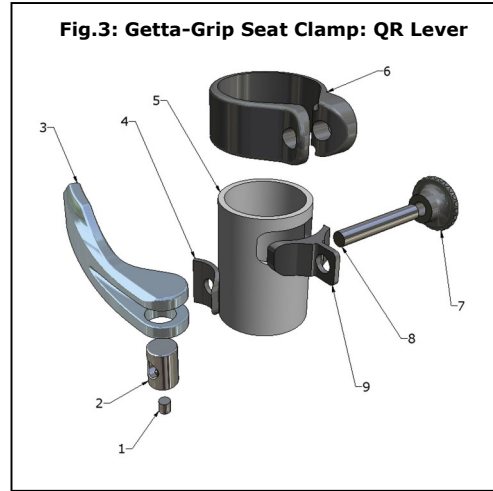

Fig.3: Getta-Grip Seat Clamp: QR Lever

QR Lever Type: Fig.3

No tools required.

(Note, refer to the seat-pin manufacturers instructions in conjunction with these notes).

To Adjust the seat height with the QR Lever assembly fitted, simply undo the QR Lever (3) from the Closed position to the Open position. Next adjust the height of the Seat Pin to the desired level, and close the QR lever (3) from the Open position to the Closed position. The QR closing force can be adjusted by turning the QR Adjuster Bobbin (7) clockwise or anti-clockwise before closing the QR Lever (3).

3.1.2: WHYTE 19 COCKPIT ADJUSTMENTS

- Seatpost:** Easton EC70, 27.2mm X 350mm
- Saddle:** Fi'zi:k Nisene with CrMo Rails
- Bar:** Easton Monkeylite XC Low Rise, 31.8mm OD
- Stem:** Easton EA50, 6 deg Rise, 31.8mm Bar Clamp
- Shift Levers** Shimano XT
- Brake Levers** Hope Hydraulic Disc

- Refer to manufacturers instructions
- Refer to manufacturers instructions
- Refer to manufacturers instructions
- Refer to manufacturers instructions
- Refer to manufacturers instructions
- Refer to manufacturers instructions

2.2: GEOMETRY

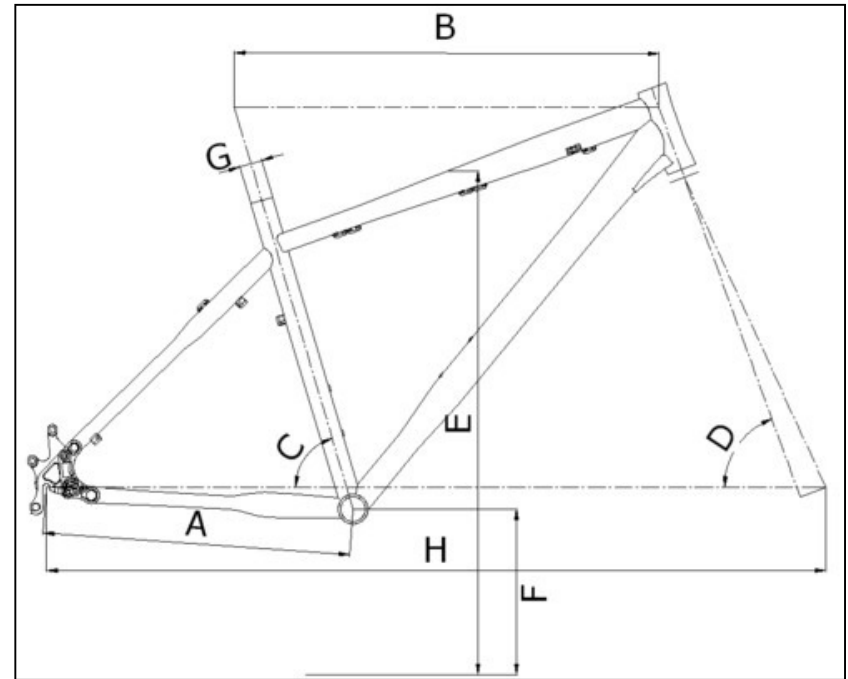

2.2.1: WHYTE 19 TRAIL, TI & STEEL 631

	Small (showroom)	Medium (showroom)	Large (showroom)
Head Angle (D)	67.7 - 68.2°	67.7 - 68.2°	67.7 - 68.2°
Seat Angle (C)	72.2 - 72.7°	72.2 - 72.7°	72.2 - 72.7°
Top Tube (B)	565.1mm	584.5mm	609.6mm
BB Height (F)	310.6mm - 316.8mm	310.6mm - 316.8mm	310.6mm - 316.8mm
Stand Over (E)	754.7mm	780.1mm	803.4mm
Wheel Base (H)	1065.3mm - 1082.5mm	1085.2mm - 1102.4mm	1111.1mm - 1128.3mm
Chain Stay (A)	415mm - 435mm	415mm - 435mm	415mm - 435mm
Seat Post (G)	30.9mm	30.9mm	30.9mm

2.2.2: WHYTE 901 & 905

	Small (showroom)	Medium (showroom)	Large (showroom)
Head Angle (D)	68.0°	68.0°	68.0°
Seat Angle (C)	72.5°	72.5°	72.5°
Top Tube (B)	565.1mm	584.5mm	609.6mm
BB Height (F)	314.1mm	314.1mm	314.1mm
Stand Over (E)	754.7mm	780.1mm	803.4mm
Wheel Base (H)	1076.0mm	1096.2mm	1123.0mm
Chain Stay (A)	425mm	425mm	425mm
Seat Post (G)	30.9mm	30.9mm	30.9mm

2.2.3: WHYTE 19 C, RACE & WORKS XX

	Small (showroom)	Medium (showroom)	Large (showroom)
Head Angle (D)	70.0°	70.0°	70.0°
Seat Angle (C)	73.5°	73.5°	73.5°
Top Tube (B)	583.5mm	600.9mm	614.0mm
BB Height (F)	305mm	305mm	305mm
Stand Over (E)	773.7mm	796.8mm	816.5mm
Wheel Base (H)	1077.5mm	1093.0mm	1107.9mm
Chain Stay (A)	420mm	420mm	420mm
Seat Post (G)	30.9mm	30.9mm	30.9mm

Note:

*Showroom' Geometry is without rider.

* Refers to Chain Stay length with dropout plates set to '0'

3.0: PREPARATIONS FOR RIDING

3.1: MAKING ADJUSTMENTS

3.1.1: WHYTE GETTA-GRIP SEAT CLAMP

The Getta Grip seat clamp design is a patented design to allow adjustment of the saddle height by either the use of a QR Lever, or bolt-up method. This manual covers both styles of clamps.

Item:	Description
1	Whyte Seat Clamp Band
2	T-Pad
3	Whyte Main Frame
4	Barrel Nut
5	M6 x 30mm Fastener
6	M6 Washer

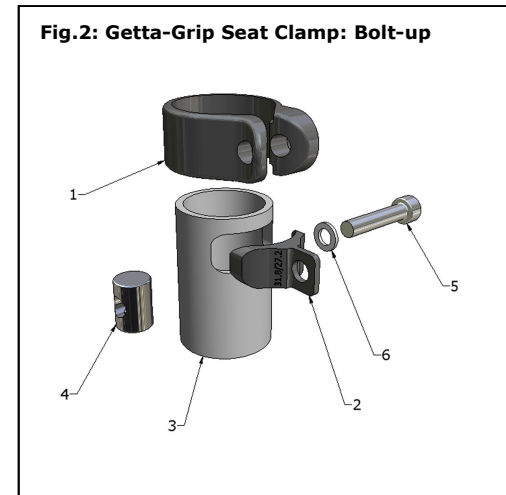

Fig.2: Getta-Grip Seat Clamp: Bolt-up

Bolt-up Type: Fig.2

Tools Required: 5mm Allen Key

(Note, refer to the seat-pin manufacturers instructions in conjunction with these notes).

To adjust the seat height, using the 5mm Allen key, undo the M6 bolt (5) just enough to allow the seat-pin to slide freely up and down. Set the height to the desired level, and re-tighten the M6 bolt (5) with the 5mm Allen Key just enough so as to prevent the seat-pin from slipping down and twisting.